

SIMRAD[®]

V5035

Class A / Inland AIS

Operator and Installation Manual
English



www.navico-commercial.com

Preface

Copyright

Copyright © 2022 Navico Holding AS.

Trademarks

®Reg. U.S. Pat. & Tm. Off, and ™ common law marks.

Visit www.navico.com/intellectual-property to review the global trademark rights and accreditations for Navico Holding AS and other entities.

- Navico® is a trademark of Navico Holding AS.
- Simrad® is a trademark of Kongsberg Maritime AS, licensed to Navico Holding AS.
- NMEA®, NMEA 0183® and NMEA 2000® are trademarks of the National Marine Electronics Association.

Disclaimer

Navico is devoted to publish and maintain this product manual. As we continue to improve our AIS products to satisfy all customers' needs, information in this document is subject to change without notice. Navico does not make any representations or warranties (implied or otherwise) regarding the accuracy and completeness of this document and shall in no event be liable for any loss of profit or any commercial damage, including but not limited to special, incidental, consequential, or other damage.

Safety warning





It is important to know that AIS is designed for the purpose of anti-collision and serves as a complement to navigation. It is not the absolute navigational equipment and does not replace any navigational system installed on board.

This device is meant to enhance situational awareness and may not prevent vessel collisions in all circumstances. It is your obligation to be aware of your surroundings and to ensure safe operation of the vessel.

Any AIS device cannot guarantee monitoring and receiving signals from all vessels in the surroundings unless those vessels are equipped with AIS devices.

 The coastline map in this transponder is neither verified nor approved by Hydrographic Authorities. It is not an Electronic Chart System and therefore should not be used for navigation. The information provided by the coastline map is for reference only and should be used together with other navigation sources and devices.

 **Electrical shock hazard**
Improper disassemble or modification could cause electrical shocks, fire, or personal injury.
Only qualified personnel could work on the interior of the equipment.

 **Make sure the power source and power input match**
Incorrect power sources will damage the equipment and may even result in fire.
Please ensure the correct power input on the adaptor before installation.

 **Avoid direct contact with rain or splashing water**
Electrical shock or fire could be resulted if water leaks into the equipment.

Note/information

→ **Note:** Important notices and information are noted in this manual.

Product category

This product is categorized as “protected” in accordance with the requirements as defined in IEC 60945.

Compass safe distance

Safe distance to the transponder (and junction box) unit is:

- Standard-magnetic-compass: 0.50 m
- Steering-magnetic-compass: 0.40 m

RF exposure safe distance

SIMRAD V5035 has been tested and meets applicable limits for radio frequency (RF) exposure. This device generates and radiates RF electromagnetic energy and requires a Maximum Permissible Exposure of 1.9m during operation.

Hardware/software version

- Hardware version: A701-0xx
- Software version: 1.0.6.xx

The model name/number, hardware information, and firmware (software) version of the transponder can be identified through MKD at MENU/DIAGNOSTICS/VERSION.

The software maintenance/upgrade of the transponder can be carried out on board via USB interface. The onboard documentation as described in Appendix C can be used to assist reflecting software maintenance records.

Type approval

The SIMRAD V5035 AIS transponder complies with applicable international standards and is type approved in accordance with the European Marine Equipment Directive and CCNR standard for Inland AIS.

Declaration of conformity

Navico declare under our sole responsibility that this V5035 conforms with the requirements of the European Council Directive 2014/90/EU on Marine Equipment. All compliance documents are available on the product's section on the following website: www.navico.com/commercial.

Disposal instruction

Do not dispose of this device with unsorted waste.

Improper disposal may be harmful to the environment and human health. Please refer to your local waste authority for information on return and collection systems in your area.

Contact information

For sales, service and technical supports, contact your local Simrad representatives or Simrad at: www.navico-commercial.com.

Contents

8 What is AIS?

10 System overview

- 10 Product description
- 11 Main features
- 11 Interconnection diagram

12 Installation

- 12 Equipment in the box
- 13 Installation procedures
- 13 RF cable requirements
- 14 VHF antenna installation
- 14 GPS antenna installation
- 15 Mounting SIMRAD V5035
- 20 External connectors (transponder unit)
- 21 External connectors (junction box)
- 24 Connecting extension cable
- 25 Connecting the power supply
- 25 Configuring the V5035

27 Operation

- 27 Panel description
- 30 Display modes
- 35 Entering text
- 38 Menu tree overview
- 42 Messages
- 45 Inland messages
- 49 Navigation status
- 59 Ship setting
- 66 Inland setting
- 68 Transceiver
- 69 System configuration
- 75 Diagnostics

78 Technical specifications

- 78 Applicable standards
- 78 VHF transceiver

| | |
|----|---------------------------|
| 78 | DSC receiver |
| 79 | GPS receiver (internal) |
| 79 | Power supply |
| 79 | LCD display |
| 79 | Keypad and knob |
| 79 | Connection interface |
| 80 | Environmental |
| 80 | Physical |
| 80 | Pilot plug |
| 80 | NMEA 2000 PGN information |

82 Mechanical dimensions

| | |
|----|----------------------------------|
| 82 | V5035 transponder main unit |
| 84 | Junction box |
| 84 | Extension cable |
| 85 | Mounting template (not to scale) |
| 85 | VHF antenna |
| 86 | GPS antenna |
| 87 | Pilot plug |

88 Troubleshooting

89 GN70/MX61X AIS operation

| | |
|----|---------------------------------------|
| 90 | Target symbols |
| 90 | Viewing information about AIS targets |
| 91 | Vessel filter |
| 92 | Vessel alarms |

93 Abbreviations

96 Appendix A

120 Appendix B

122 Appendix C

4

What is AIS?

The Automatic Identification System (AIS) is a Very High Frequency (VHF) radio broadcasting system that transfers packets of data over the VHF data link (VDL) and enables AIS equipped vessels and shore-based stations to exchange identification information and navigational data. Ships with AIS transponders continually transmit their ID, position, course, speed and other data to all nearby ships and shore stations. Such information can aid greatly in situational awareness and provide a means to assist in collision avoidance.

AIS equipment is standardized by ITU, IEC, IALA and IMO and is subject to approval by a certification body. The following AIS devices have been developed for variant applications.

AIS Class A

Mandated by the IMO for vessels of 300 gross tonnages and upwards engaged on international voyages, cargo ships of 500 gross tonnages and upwards, as well as passenger ships. It transmits typically on 12.5 watt output power.

AIS Class B

Provides limited functionality and is intended for non-SOLAS commercial vessels and recreational vessels. It transmits typically on 2 watt output power.

AIS Receiver

Only receives AIS signal and does not have transmitter to send out AIS signal. Suitable for recreational vessels that do not want to send out its vessel information.

AIS Base Station

Is provided by aids-to-navigation authorities to enable the ship to shore / shore to ship transmission of information. Networked AIS Base Stations can assist in providing overall maritime domain awareness.

AIS AtoN (Aids to Navigation)

Provides an opportunity to transmit position and status of buoys and lights through the same VDL, which can then show up on AIS-ready devices within the range.

AIS SART

Search and Rescue Transmitter using AIS can be used to help determining the location of a vessel in distress. It is typically used on life rafts.

AIS on Search and Rescue (SAR) Aircraft

Used on airplanes and helicopters to assist search and rescue operation.

2

System overview

Product description

The SIMRAD V5035 is a new generation AIS Class A transponder fully compliance with IMO, IEC, and ITU international standards. It provides a compact single box solution, easy to install and operate. The unit is designed with advanced technology which sets a new standard for quality, performance, and value. It is an excellent choice for SOLAS vessels, commercial vessels, and professional vessels.



The V5035 consists of a transceiver radio unit, an integrated GPS receiver, a controller unit, and a color 3.5" LCD display with menu keypads. The radio has three receivers - two TDMA receivers and one DSC receiver. The transmitter alternates its transmission between the two operating TDMA. The controller unit creates and schedules data packets (containing dynamic, static and voyage related data) for transmission based on the IMO performance standard for AIS.

The V5035 can connect to the ship's sensors as required by IALA guidelines through an external junction box (supplied). The unit can also interface external navigation and presentation systems that support IEC 61162-1 related sentences. It is also capable for connection to Long Range system like Inmarsat C. The V5035 supports IMO and Inland AIS which is configurable by the software.

The color LCD display and menu keypads provide an intuitive graphical user-friendly interface to the system. It can display the location of other vessels, aids to navigation and search and rescue vessels. The AIS transmit and receive status are shown on the screen which helps user to know the working status of the unit easily. The LCD and keypad can also be used to send and receive messages, perform configuration as well as supervise the systems status.

Main features

- IMO Compliant Class-A AIS system
- Supplied as a standalone system with junction-box, GPS antenna and Pilot Plug
- Easily integrates with Simrad GPS and Charting systems via NMEA2000 interface.
- Perfect complement to Simrad IMO GPS/GNSS systems (GN70, MX610, MX612)
- Multiple sensors input ports and bi-directional data ports
- Control knob and keypad for easy operation
- Color 3.5" LCD display
- Support type P of BAM function type

Interconnection diagram

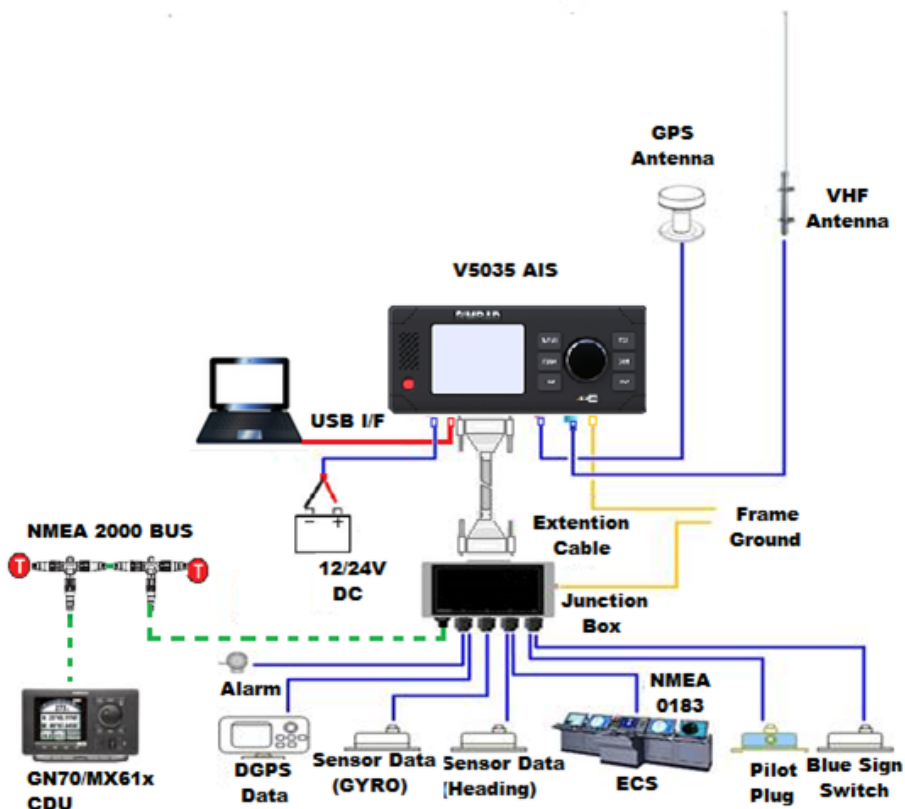

3

Installation

Equipment in the box

The standard supply in the package includes the following items. Please contact your local representative if an item is missing.

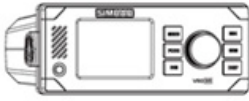

Class A AIS Transponder unit
000-12249-001



Junction box
000-12324-001



Pilot plug
000-12325-001

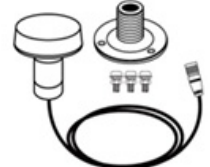

GPS antenna ANT-21
with 10 m cable
000-12326-001



U-shaped mounting
bracket kit
000-12327-001



37-pin extension
cable 1.8 m
000-12328-001



3-pin power
cable 1 m
000-12329-001



USB to Mini-USB
cable 1.8 m
Included



Junction box
mounting kit
Included

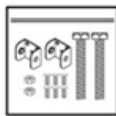

Panel mount
holder kit
Included



Panel mount cutting
template
Included



User manual
988-10838-003

| Parts list | Part number |
|--|---------------|
| V5035 Class A AIS Transponder unit w/GPS antenna and USB cable | 000-12249-001 |
| Junction box | 000-12324-001 |
| Pilot plug | 000-12325-001 |
| U-bracket mounting kit | 000-12327-001 |
| 37-pin extension cable | 000-12328-001 |
| 3-pin power cable | 000-12329-001 |
| Panel mount holder kit | 000-12330-001 |
| User manual | 988-10838-003 |

Installation procedures

Familiarize yourself with the manual content before you begin installation. Use the following recommended steps for installation:

1. Mount the transponder unit to a desired location.
2. Mount junction box.
3. Install VHF antenna.
4. Install GPS antenna.
5. Connect all external sensors and data interfaces to the junction box.
6. Connect all required cables to the main transponder unit.
7. Power on the main transponder unit.
8. Complete configuration settings.
9. Perform system functional test .

RF cable requirements

The following RF cables are recommended to install the V5035:

- VHF Antenna Cable
Type: 5D-FB or equivalent
Connector: SO-239 (Male)
- GPS Antenna Cable
Type: RG58A/U or equivalent
Connector: TNC (Male)
Cable and connector are supplied as part of the GPS antenna.

VHF antenna installation

The quality and positioning of the antenna are the most important factors dictating AIS performance. It is recommended that a VHF antenna with omni directional vertical polarization be specifically tuned for AIS operation band. Since the range of VHF signals is largely decided by line of sight distance, the VHF antenna should be placed as high as possible and at least 5 meters away from any constructions made of conductive materials.

To avoid interference, the VHF antenna location should be placed as shown in the diagram below:

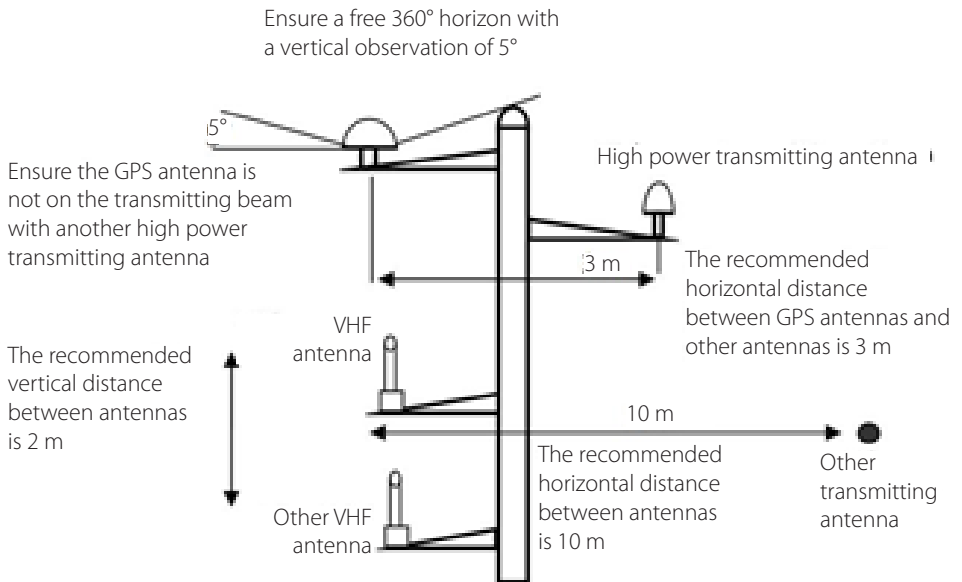

GPS antenna installation

The GPS antenna must be installed where it has a clear view of the sky, so that it may access the horizon freely with 360° degrees, with a vertical observation of 5 to 90 degrees above the horizon.

GPS antenna location

Enter the GPS antenna location data in "SHIP SETTING" after the installation.

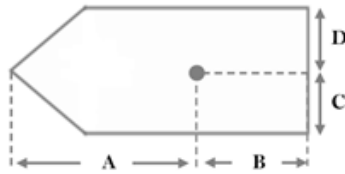

Mounting SIMRAD V5035

Use the following guidelines to check the installation location for your AIS transponder:

- The AIS transponder should be mounted in a location that is accessible and readable to user at all time.
- The transponder should be installed in a protected environment away from direct rain and water contact.
- The transponder is designed to operate in an environment with 15°C ~ 55°C temperature. Environments with excessive heat may cause damages to the transponder.
- The transponder should not be installed near flammable or hazardous environments.
- The AIS transponder should be installed at least 0.5 m away from magnetic compasses.

Mounting transponder

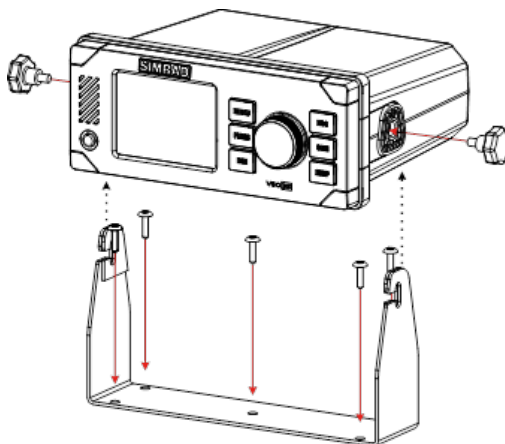

Panel mounting

1. Line up the mounting template on control panel to sketch an outline for the cutting area.
2. Using a jigsaw carefully cut along the sketched cutting area.
3. If necessary, clean up edge with glass paper or file.
4. Mount the transponder through the opening.
5. From the rear, install the mounting brackets with the M3X8 screws.
6. Apply the mounting bracket screw on each side for a firm fix.

→ **Note:** The brackets are directional so ensure the correct one is fitted to each side.

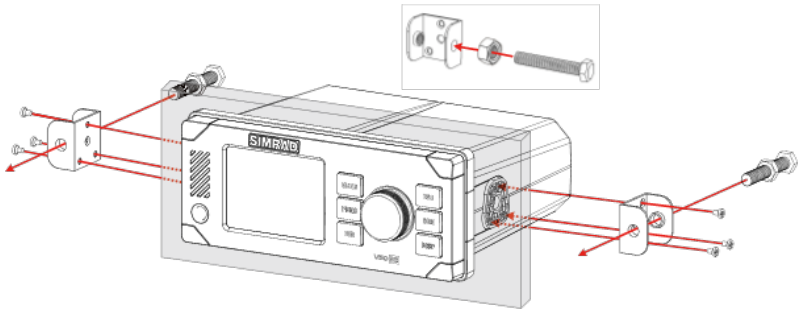

Panel mounting (1)

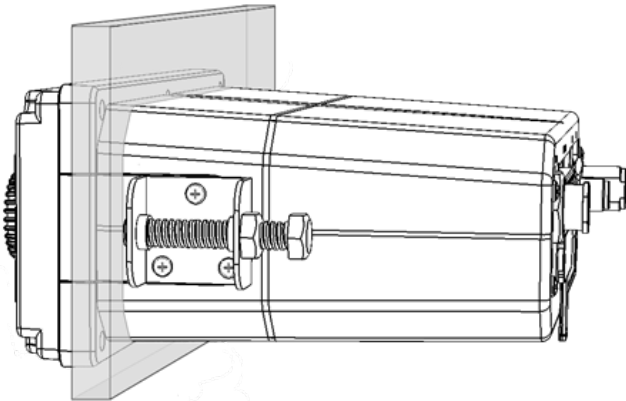

Panel mounting (2)

Mounting junction box

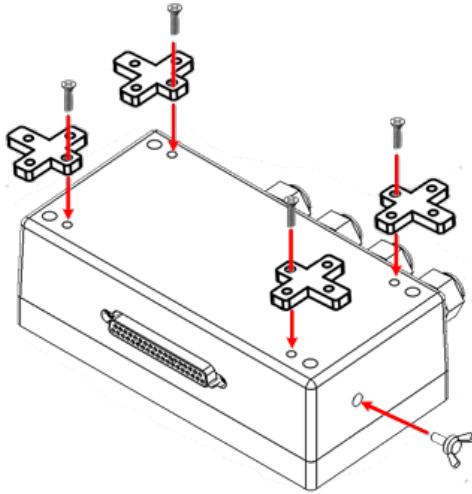

Mounting junction box (1)

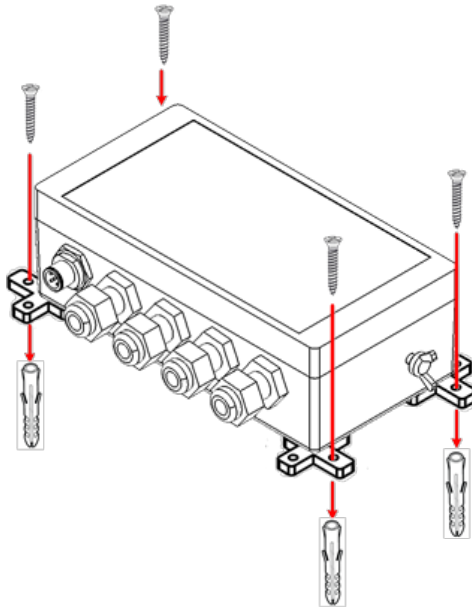

Mounting junction box (2)

Mounting pilot plug

The pilot plug provides a connecting interface to pilots and other mariners to connect their own PC or other portable device to V5035 on board.

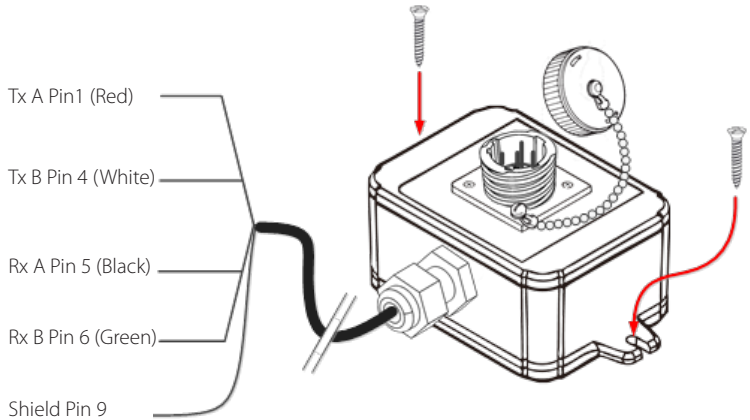

| Pin number | Function | Wire color |
|------------|-----------------|------------|
| Pin 1 | Tx A | Red |
| Pin 2 | -- | |
| Pin 3 | -- | |
| Pin 4 | Tx B | White |
| Pin 5 | Rx A | Black |
| Pin 6 | Rx B | Green |
| Pin 7 | -- | |
| Pin 8 | -- | |
| Pin 9 | Shield (ground) | |

Connecting to MX5035 junction box

Use the following guidelines to connect the pilot plug to the V5035 junction box. Refer to **External connectors (junction box)** page

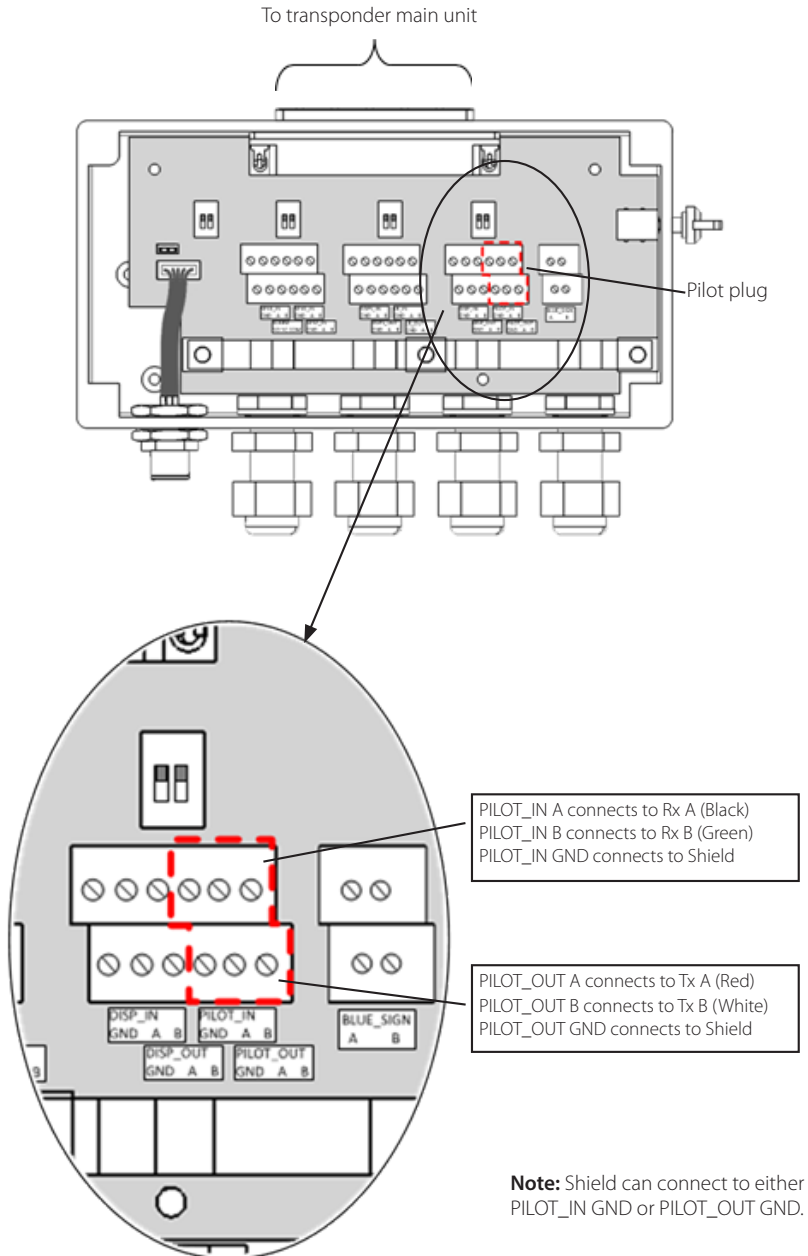

External connectors (transponder unit)

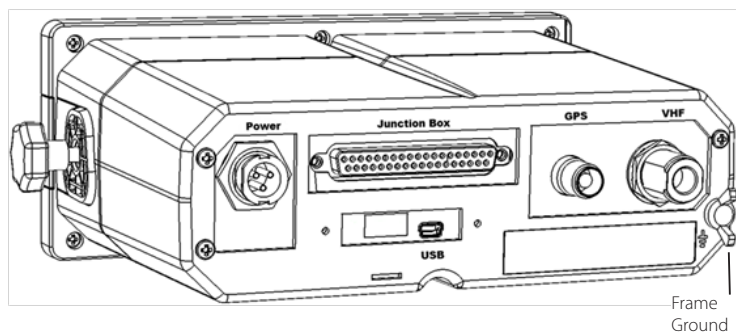

| Name | Description | Type of connector |
|--------------|--------------------------------------|--------------------|
| VHF | VHF antenna connector | SO-239 (female) |
| GPS | GPS antenna connector | TNC (female) |
| Power | Power input connector | Round type, 3 pins |
| USB | USB connection to PC | Mini type USB |
| Junction box | Extension connection to Junction box | D-Sub 37 pins |
| Frame ground | Connect to ship frame | |

Vessel power supply requirement

Connect to the ship's power source, ideally an uninterrupted power supply (UPS), through a 2-pole switched fused supply to allow isolation for servicing. Power requirement is 12-24 V DC typical 5 A minimum. Required conductor area, cable length 0-10 m is 1.5 mm² \varnothing minimum.

- **Note:** The Class A power supply requirement should comply with IMO guidelines for the class of vessel concerned. National authorities and classification societies may have their own power supply requirements; these should also be considered.
- **Note:** Some boats require frame ground connection of all electronic

devices on the ship frame.

External connectors (junction box)

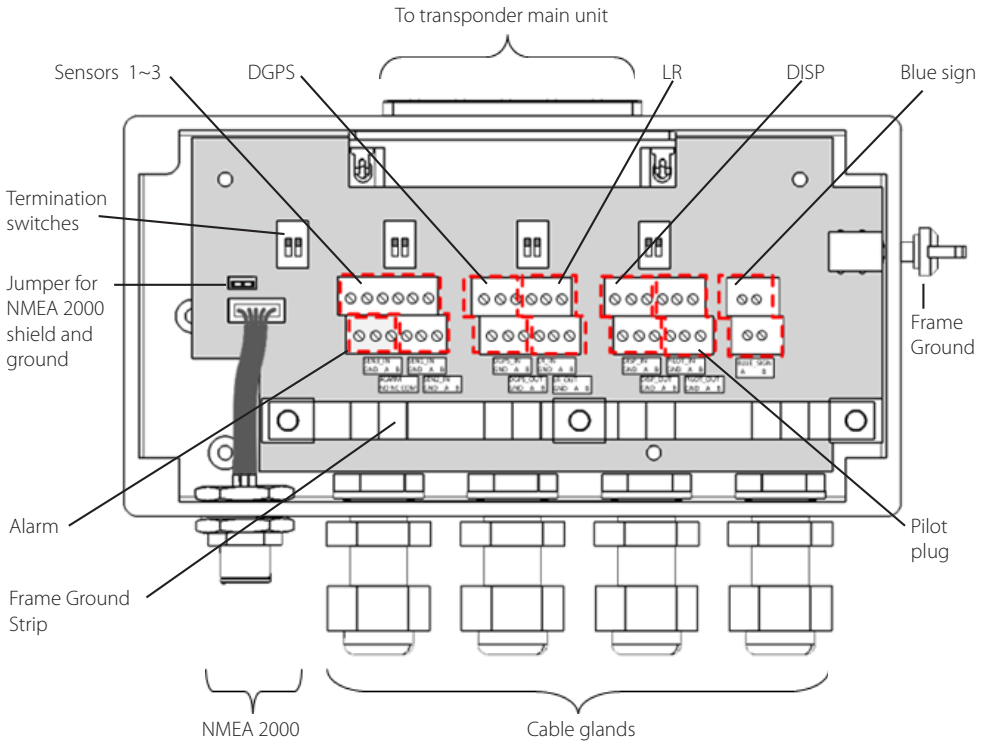

| Connector | Label name | Description | Function usage |
|-----------|-------------|------------------|--|
| Sensor 1 | SEN1_IN GND | Sensor 1 ground | Connect to data sources such as heading, gyro, or other type of sensors. |
| | SEN1_IN A | Sensor 1 input A | |
| | SEN1_IN B | Sensor 1 input B | |
| Sensor 2 | SEN2_IN GND | Sensor 2 ground | Connect to data sources such as heading, gyro, or other type of sensors. |
| | SEN2_IN A | Sensor 2 input A | |
| | SEN2_IN B | Sensor 2 input B | |
| Sensor 3 | SEN3_IN GND | Sensor 3 ground | Connect to data sources such as heading, gyro, or other type of sensors. |
| | SEN3_IN A | Sensor 3 input A | |
| | SEN3_IN B | Sensor 3 input B | |

| Connector | Label name | Description | Function usage |
|-------------|---------------|-----------------------|---|
| Pilot plug | PILOT_IN GND | Input Ground | Pilot plug port |
| | PILOT_IN A | Input A | |
| | PILOT_IN B | Input B | |
| | PILOT_OUT GND | Output Ground | |
| | PILOT_OUT A | Output A | |
| | PILOT_OUT B | Output B | |
| Alarm | ALARM NO | Alarm normally open | |
| | ALARM NC | Alarm normally closed | |
| | ALARM COM | Alarm common | |
| DGPS input | DGPS_IN GND | DGPS input ground | DGPS sensor |
| | DGPS_IN A | DGPS input A | |
| | DGPS_IN B | DGPS input B | |
| DGPS output | DGPS_OUT GND | DGPS output ground | DGPS sensor |
| | DGPS_OUT A | DGPS output A | |
| | DGPS_OUT B | DGPS output B | |
| LR input | LR_IN GND | LR input ground | Long range input |
| | LR_IN A | LR input A | |
| | LR_IN B | LR input B | |
| LR output | LR_OUT GND | LR output ground | Long range output |
| | LR_OUT A | LR output A | |
| | LR_OUT B | LR output B | |
| Display | DISP_IN GND | DISP input ground | Connect to the data output of an external display system such as ECDIS. |
| | DISP_IN A | DISP input A | |
| | DISP_IN B | DISP input B | |
| | DISP_OUT GND | DISP output ground | Connect to the data input of an external display system such as ECDIS. |
| | DISP_OUT A | DISP output A | |
| | DISP_OUT B | DISP output B | |
| Blue sign | BLUE_SIGN A | | Connect to a blue sign switch. |
| | BLUE_SIGN B | | |

- **Note:** RTCM-SC-104 beacon input is currently not implemented by the DGPS_IN input.
- **Note:** Suitable electric wire gauge (single wire) for installing Junction Box: AWG 26 ~ 16. See diagram below.

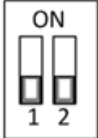
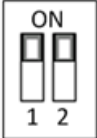

| Item | Usage |
|--|--|
| Termination switches | <p>The switches provide line termination configuration.</p> <p>Termination off Termination on</p> <div style="display: flex; justify-content: space-around; align-items: center;"> <div style="text-align: center;">  </div> <div style="text-align: center;">  </div> </div> |
| Jumper for NMEA 2000 shield and ground | <p>The jumper's purpose is to wire together NMEA2000 cable's shield and ground. Depending on your scenario, you may choose not to connect them together.</p> |

Connecting extension cable

Use the 37-pin- extension cable (1.8M) provided in the package connect V5035 to the junction box.

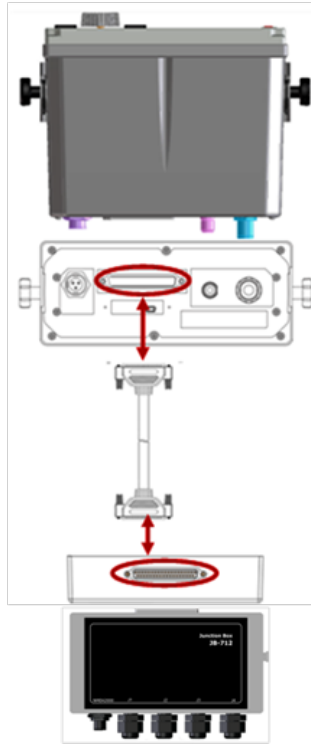

Connecting V5035 with junction box

Connecting to power supply

The V5035 requires a 12V or 24V DC power supply (9.6 to 31.2V operation range) capable of supplying 8A peak current. The red wire and the black wire on the 3-pin cable are used to connect the power supply's positive and negative terminals. A 10 Amp fuse or circuit breaker must be used in the connection between the power supply and the unit.

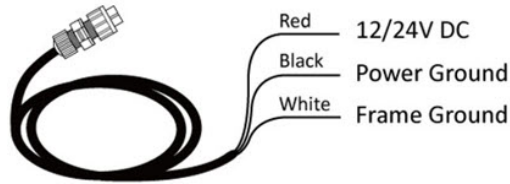

V5035 power connection

Configuring the V5035

The following items must be completed before initial configuration.

1. Ensure VHF and GPS antennas are connected to the transponder main unit.
2. Ensure the 37-pin-connector extension cable is connected from the transponder main unit to the junction box.
3. Ensure the power cable is connected and supplied with stable voltage/current power source.
4. Ensure applicable external devices are connected through the junction box.

Initial configuration

The initial configuration, particular, MMSI (Maritime Mobile Service Identity) number must be done before operation. The following initial configuration is required:

1. Setup 1: MMSI should be correctly programmed.

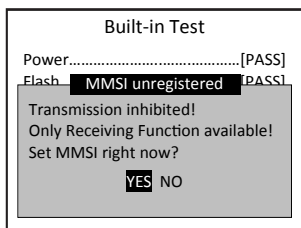

2. Press **MENU** and select main menu item **SHIP SETTING**.
(Password required, default is "0000")
3. Set up call sign, ship name, ship type, external/internal GPS antenna position in **OWN SHIP**.

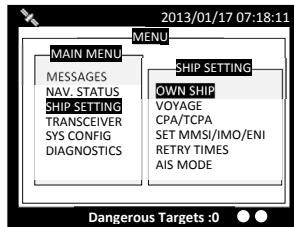

4. If IMO identification number is applicable, select main menu item **SET MMSI/IMO/ENI** to set up IMO number.

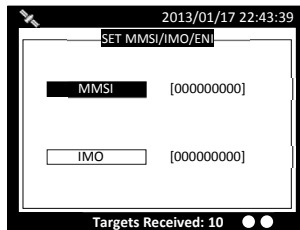

For more information, refer to SHIP SETTING, page 59.

4

Operation

Panel description









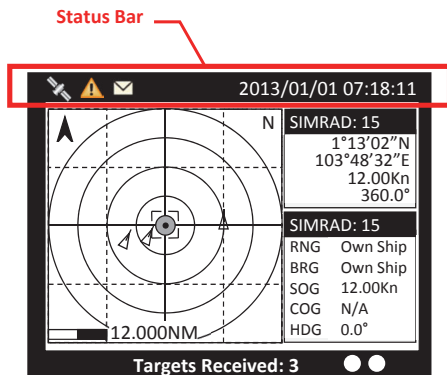

| Item | Name | Description |
|------|--------------|---|
| 1 | Power switch | Power On/Off (push over 5 seconds) |
| 2 | Beeper | Sounds when buttons are pushed and by MOB alarm |
| 3 | Display | 3.5" LCD color screen |

| Key | Description |
|------|--|
| MENU | Return to main menu / detail menu select |
| FUNC | Different function on display mode (Zoom In/Out, etc) and has different roles in submenus |
| DIM | Adjust dim degree (refer to page 35) |
| Knob | Rotate to select, press to confirm |
| DISP | Change to different display modes: 1. Coastal view 2. Radar view 3. AIS target list 4. Dangerous target list 5. Own ship detail 6. GPS satellite information 7. Region setting list |
| SRM | Emergency SRM broadcast |
| ESC | Cancel/Back to main menu, or press and hold for 3 seconds to access Active Alert list |

Status bar

The status bar constantly indicates date (YYYY/MM/DD), time, GPS status, ALR, and SRM.

















| Icon | Description |
|---|--|
|  | GPS Status: position fixed |
|  | GPS Status: non-fixed |
|  | ALR Status: alarm messages occurs |
|  | Inbox SRM: unread coming SRM message |
|  | SART/MOB: SART or MOB message received |
|  | EMMA warning (RFM23): warning received |
|  | ETA/RTA: message received |
|  | Water levels (RFM24): message received |

Transmission and reception bar



The Transmission & Reception bar constantly displays real time status of transmissions and receptions on any display modes. The 3 default displayed messages are received AIS targets, dangerous targets, and Tx power level.



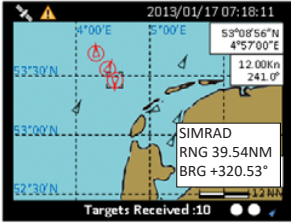
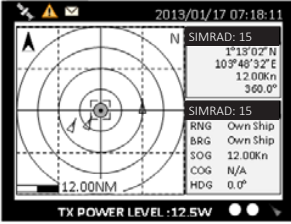
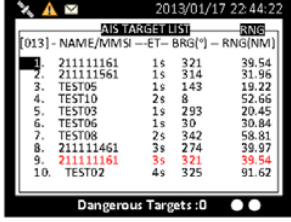
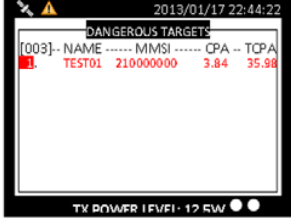

| Item | Name | Function | |
|------|--|--|---|
| 1 | Text banner | Shows the numbers of “Targets Received” and “Dangerous Targets” automatically. | |
| 2 | Indicators  Ch.87 Ch.88 | <ul style="list-style-type: none">  No transmissions & receptions: No flash  Reception of AIS message: Flash green color  Transmission of AIS message: Flash red color | |
| 3 | Function Icon (Coastal view only) | <ul style="list-style-type: none">  zoom in/out  up/down  left/right  target selected  SART/MOB | <p>The function icon indicates the knob’s action differently in operations.</p> <p>Push FUNC enables the knob to operate different actions</p> <p>SART/MOB alert icon only available when valid SART or MOB target is received</p> |
| | Function Icon (Radar view only) | <ul style="list-style-type: none">  zoom in/out  target selected  SART/MOB | |
| 4 | Inland mode |  | Indicate the system is running Inland mode |
| | Blue sign |  | Indicate Blue Sign device is connected |

Display modes



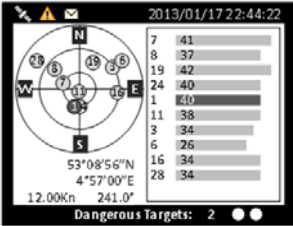

For quick access, rotate display modes by pressing the **DISP** button.









| Mode | Screenshot | Purpose |
|-----------------------|---|---|
| Coastal view |  | Display all targets on basic coastline map (Refer to Coastal View, page 33) |
| Radar view |  | Displays all targets on radar view (Refer to Radar View, page 34) |
| AIS target list |  | Shows all received ship data (Refer to AIS Targets, page 50) |
| Dangerous target list |  | Shows all dangerous AIS targets presently (Refer to Dangerous List, page 58) |
| Own ship detail |  | Shows all the details of own ship (Refer to Own Ship detail, page 49) |

| GPS satellite information |  <p>2013/01/17 22:44:22</p> <p>7 41 8 37 19 42 24 40 1 10 11 38 3 34 6 26 16 34 28 34</p> <p>53°08'56"N 4°57'00"E 12.00Kn 241.0°</p> <p>Dangerous Targets: 2 ●●</p> | Shows the GPS satellite current usage status (Refer to GPS Status, page 7675) | | | | | | | | | | | | | | | | | | | | | | | | |
|---------------------------|--|---|--------|-----------|----------|-----|-------------|----------|-----|-------------|----------|-----|-------------|----------|-----|-------------|----------|-----|-------------|----------|-----|-------------|----------|-----|-------------|---|
| Region setting list |  <p>2013/01/17 22:44:22</p> <p>REGION SETTING LIST</p> <table border="1"> <thead> <tr> <th>Region No</th> <th>Source</th> <th>Date/Hour</th> </tr> </thead> <tbody> <tr> <td>Region 1</td> <td>ACA</td> <td>12/01/02 11</td> </tr> <tr> <td>Region 2</td> <td>ACA</td> <td>12/01/02 11</td> </tr> <tr> <td>Region 3</td> <td>N/A</td> <td>11/11/01 00</td> </tr> <tr> <td>Region 4</td> <td>N/A</td> <td>11/11/01 00</td> </tr> <tr> <td>Region 5</td> <td>N/A</td> <td>11/11/01 00</td> </tr> <tr> <td>Region 6</td> <td>N/A</td> <td>11/11/01 00</td> </tr> <tr> <td>Region 7</td> <td>N/A</td> <td>11/11/01 00</td> </tr> </tbody> </table> <p>Region in Use [Region 9] I. Zone Status [No]</p> <p>Dangerous Targets :0 ●●</p> | Region No | Source | Date/Hour | Region 1 | ACA | 12/01/02 11 | Region 2 | ACA | 12/01/02 11 | Region 3 | N/A | 11/11/01 00 | Region 4 | N/A | 11/11/01 00 | Region 5 | N/A | 11/11/01 00 | Region 6 | N/A | 11/11/01 00 | Region 7 | N/A | 11/11/01 00 | Show all the Region of own ship (Refer to Own Ship detail, page 49) |
| Region No | Source | Date/Hour | | | | | | | | | | | | | | | | | | | | | | | | |
| Region 1 | ACA | 12/01/02 11 | | | | | | | | | | | | | | | | | | | | | | | | |
| Region 2 | ACA | 12/01/02 11 | | | | | | | | | | | | | | | | | | | | | | | | |
| Region 3 | N/A | 11/11/01 00 | | | | | | | | | | | | | | | | | | | | | | | | |
| Region 4 | N/A | 11/11/01 00 | | | | | | | | | | | | | | | | | | | | | | | | |
| Region 5 | N/A | 11/11/01 00 | | | | | | | | | | | | | | | | | | | | | | | | |
| Region 6 | N/A | 11/11/01 00 | | | | | | | | | | | | | | | | | | | | | | | | |
| Region 7 | N/A | 11/11/01 00 | | | | | | | | | | | | | | | | | | | | | | | | |

Target symbol descriptions





Symbols for each AIS target on the radar view are described below:

| Symbol | Description |
|---|--|
|  | GPS Reception: Normal / Color: Black and Gray Under normal GPS reception, own ship is located in the center of the radar view. |
|  | GPS Reception: No GPS / Color: Blue Without GPS reception, own ship needs to be located manually. |
|  | Color: Black Ship equipped with AIS system in the surrounding sea will appear on the radar view as an AIS target. |
|  | Color: Black / Flashing Colored Frame Use the arrow keys to select any target on the radar view. After selected, press <ENT> and the detailed information on each target can be viewed. |
|  | Color: Red / Circled Frame When distance to a ship is smaller than CPA/TCPA, the target will be circled in RED. Use the arrow keys to select the dangerous target and to view its detailed information. |

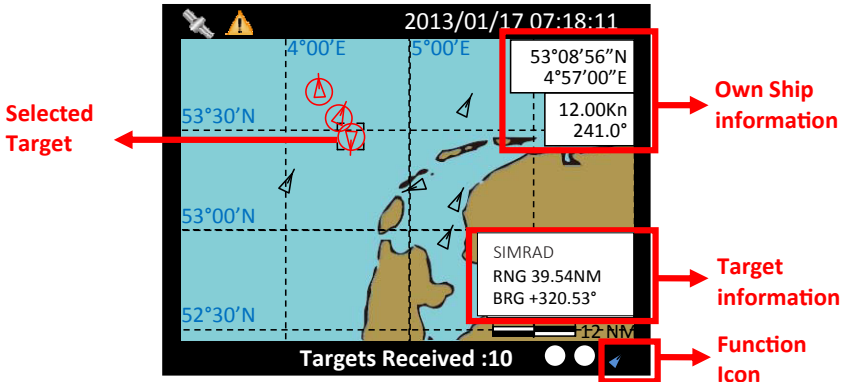
| Symbol | Description |
|--|---|
| Friend ship  | Color: Magenta If any pre-stored Friend Ship is nearby, the Friend Ship will appear in Magenta on the radar view. |
| Los signal target  | Color: Black / Red Cross If reception of an AIS target has ceased over 10 minutes, a "X" will be displayed over it. The target will disappear from the Radar View after its reception has ceased for one hour. |
| AtoN (Real)  | Color: Black / Plus Sign The icon will be displayed if any AIS AtoN (Aids to Navigation) Real is in the range of reception. |
| AtoN (Virtual)  | Color: Black / Plus Sign and Undercut The icon will be displayed if any AIS AtoN (Aids to Navigation) Virtual is in the range of reception. |
| AtoN (off position)  | Color: Red / Plus Sign The icon will be displayed if any AIS AtoN (Aids to Navigation) is in off position status. |
| SAR  | Color: Black The icon will be displayed if any air plane is in the range of reception. |
| SART  | Color: Red / Cross The icon will be displayed if any SART message is sent out. |
| Base station  | Color: Green The icon will be displayed when any base station is in the reception range. |

Coastal view



| Item | Function |
|---|---|
| Own ship information | Own-ship information for latitude, longitude, SOG and COG |
| Target information | Display the target information such as vessel name or MMSI as well as range and bearing relatively to the own ship |
| Function icon (coastal view) | Users can select one of the 5 viewing modes by pressing the FUNC button. Turn the knob to change the selected range, position, AIS target or SART/MOB target |
|  zoom in/out | The plot range can be adjusted by turning the knob which cycles through the ranges 24, 12, 6, 3, 1.5, 0.75, 0.5, 0.25, 0.125 and 0.05 nm. |
|  up/down | Turn the knob to move the map vertically |
|  left/right | Turn the knob to move the map horizontally |
|  target selected | Turn the knob to navigate between different AIS targets, while press the knob to see more details of the target. |
|  SART/MOB | This icon appears only when valid SART or MOB target is received. Turn the knob to navigate between different SART/MOB targets, press the knob to see more details of the target. |



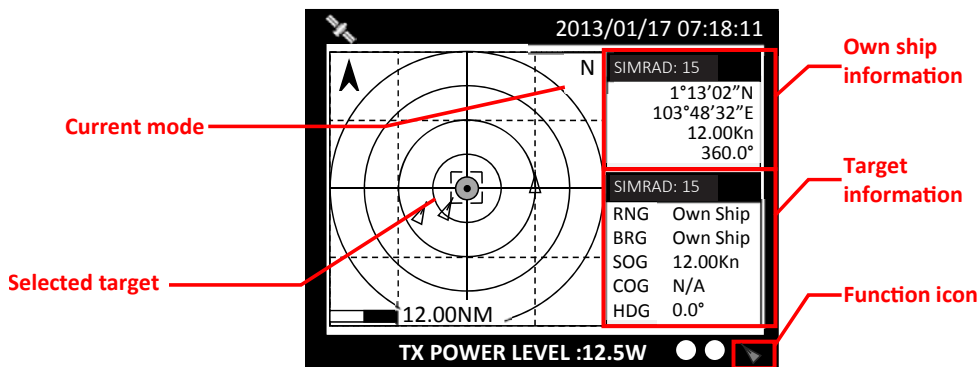

The coastline map in this transponder is neither verified nor approved by Hydrographic Authorities. It is not an Electronic Chart System and should not be used for navigation. The information provided by the coastline map is for reference only and should be used together with other navigation sources and devices.

Radar view



Radar View displays own ship and target ships' statuses, and their correlations.

On this view, the vertical grid lines are the longitudinal lines and the horizontal grid lines are the latitudinal lines. Underneath the radar view is a proportional chart scale showing the current ratio displayed.

Under Radar View, only 3 function icons are available -  Zoom In/Out,  Select Target and  SART/MOB. The operation with FUNC button is same as described in page 33.

Radar View supports three ship orientation modes, North up, Head up, and Course up. Each orientation mode is indicated by the uppercase letter (N, H, or C) on the right upper corner. The left upper corner is the north arrow indicating the direction of north.

| | | |
|---|-----------|--|
| N | NORTH UP | The chart orientation is fixed and true north is always pointing up. |
| H | COURSE UP | The orientation is determined by the own ship's traveling course. |
| C | HEAD UP | The orientation is determined by the direction of own ship's bow. |

Dimmer setting

Press the button "DIM" to enter the dimmer setting page.

| Button | Description |
|------------------------|--|
| Knob (Turn left/right) | Adjust screen brightness (decrease/increase) |
| Knob (Press) | Save and leave the page |
| DIM | Restore screen brightness to default setting (100) |
| MENU, ESC | Leave the page without saving |

Entering text

The knob on the front control panel is used for entering and editing text.

1. Turn the knob to traverse the menu items up or down. Once selected, press the knob to select the item for text entering.
2. Select a character position to edit. Turn the knob to move the cursor left or right and press the knob to confirm the position.
3. The system is now in character selection mode as the cursor position is highlighted. Turn the knob to pick an available character and press the knob for character selection.

| | | | | | | | |
|---|---|---|---|---|----|---|---|
| | A | B | C | D | E | F | G |
| H | I | J | K | L | M | N | O |
| P | Q | R | S | T | U | V | W |
| X | Y | Z | 0 | 1 | 2 | 3 | 4 |
| 5 | 6 | 7 | 8 | 9 | [| \ |] |
| ^ | _ | ! | " | # | \$ | ÷ | & |
| ' | (|) | * | + | , | - | . |
| / | : | ; | < | = | > | ? | @ |

- **Note:** Space is first character for selection.
4. Use steps 2 and 3 to finish entering all needed characters.
 5. To confirm and save, press down the knob and hold for 2 seconds.

The following illustrations show the procedure:

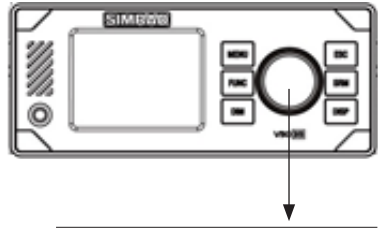

1: Traverse menu

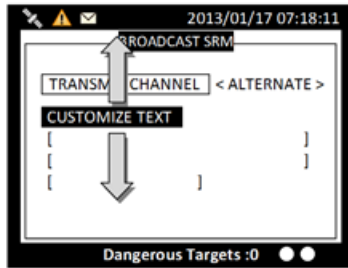

Turn knob to move up or down



Press to enter



2: Select a character position

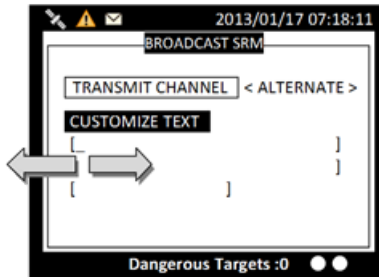

Turn knob to move left or right



Press to start editing



3: Pick character

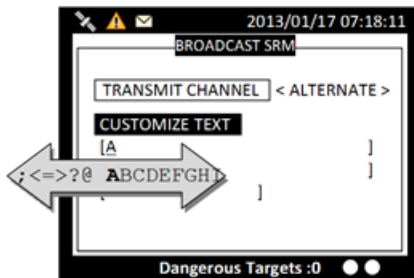

Turn knob to select character



Press to confirm



4. Confirm and save

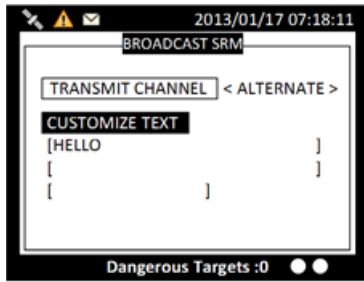

To save entered text, press and hold the knob for 2 seconds.



Menu tree overview

Press MENU button to enter MAIN MENU. Please note inland menus, Inland Messages and Inland Settings, are only available when the unit operates under inland mode.

MESSAGES

INBOX SRM (page 42)
OUTBOX SRM (page 42)
BROADCAST SRM (page 43)
ADDRESSED SRM (page 44)
LR INBOX (page 44)



INLAND MESSAGES*

ETA/RTA INBOX (page 45)
ETA OUTBOX (page 46)
CREATE ETA MSG (page 46)
POB OUTBOX (page 47)
CREATE POB MSG (page 47)
EMMA WARNING (page 48)
WATER LEVEL (page 4949)



NAV. STATUS

OWN SHIP (page 49)
AIS TARGETS (page 50)
REGION LIST (page 52)
ACTIVE ALERT (page 53)
ACTIVE BIIT LIST (page 5355)
BIIT HISTORY (page 56)
SENSOR STATUS (page 5757)
DANGEROUS LIST (page 5858)
MOB LIST (page 5858)
FRIEND SHIPS (page 5959)



SHIP SETTING

OWN SHIP (page 60 60)
VOYAGE (page 6161)
EXT TOW DIM (page 63)
CPA/TCPA (page 6363)
SET MMSI/IMO/ENI (page 6464)
RETRY TIMES (page 6566)
AIS MODE (page 6666)



INLAND SETTING*

VESSEL DATA SET. (page 6666)
ETA SETTING (page 6767)
NUMBER OF PERSON (page 6868)
BLUE SIGN SET. (page 6868)
REPORT RATE SET. (page 6868)



TRANSCEIVER

TRANSCEIVER SETTING (page 6868)



SYS CONFIG

CUSTOMIZE (page 6969)
RADAR VIEW (page 7070)
MAP CALIBRATION (page 7171)
SENSOR CONFIG (page 7171)
FACTORY (page 7271)
PASSWORD (page 7272)
LONG RANGE SET. (page 7373)
LR BCST SET. (page 7373)
DEST. TABLE SET. (page 7474)
ALARMS SETTING (page 7474)
VSWR SETTING (page 7474)



DIAGNOSTICS (page 7575)

SYSTEM ON/OFF
MEMORY TEST
SENSOR PORT
TFT-PANEL
KEYBOARD TEST
GPS STATUS
TRANSCEIVER
COMMUN. TEST
PANEL TEST
VERSION

* Inland mode only

How to access and use MAIN MENU

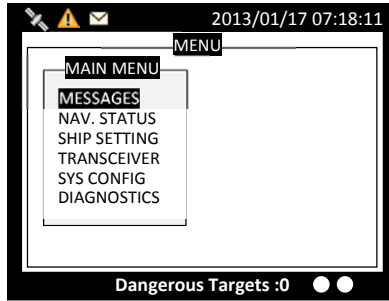

Rotate knob to select MAIN MENU items and push the knob to select sub-menu items:

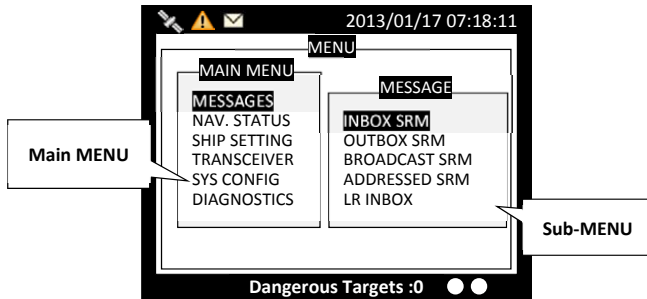

Menu item brief description

| MESSAGES | |
|-----------------|--|
| INBOX SRM | Log of safety related messages (SRM) received |
| OUTBOX SRM | Log of safety related messages (SRM) sent |
| BROADCAST SRM | Send SRM |
| ADDRESSED SRM | Send specified targeted SRM |
| LR INBOX | Log of received inquiry messages from other |
| INLAND MESSAGES | |
| ETA/RTA INBOX | Log of ETA(RFM21), RTA(RFM22) message received |
| ETA OUTBOX | Log of ETA(RFM21) sent |
| CREATE ETA MSG | Create ETA(RFM21) message |
| POB OUTBOX | Log of PERSON message (RFM55 or IFM16) sent |

| | |
|--|--|
| CREATE POB MSG | Create PERSON message (RFM55 or IFM16) |
| EMMA WARNING | Log of EMMA warning (RFM23) received |
| WATER LEVEL | Log of WATER LEVEL (RFM24) received |
| NAVIGATION STATUS (Display a variety of navigation information) | |
| OWN SHIP | Your vessel information |
| AIS TARGETS | Navigation status and boat information of other AIS-equipped vessels |
| REGION LIST | Regional information status |
| ACTIVE ALERT | Display all activated alerts. To access Active Alert, directly press and hold ESC button for 2 seconds |
| ACTIVE BIIT LIST | Display all activated BIIT |
| BIIT HISTORY | BIIT history record |
| SENSOR STATUS | Display sensor statuses |
| DANGEROUS LIST | Dangerous ship list |
| MOB LIST | MOB list of registered MOB users |
| FRIEND SHIPS | Friend ship list |
| SHIP SETTING (Basic vessel information setting) | |
| OWN SHIP | Your vessel setting (password required, default is 0000) |
| VOYAGE | Navigation setting |
| EXT TOW DIM | Extended tow dimension values setting |
| CPA / TCPA | CPA / TCPA |
| SET MMSI / IMO / ENI | Change MMSI / IMO / ENI number |
| RETRY TIMES | Times to resend messages |
| AIS MODE | Configure AIS Mode to SOLAS or INLAND |
| INLAND SETTING | |
| VESSEL DATA SET. | Configure Vessel data |
| ETA SETTING | Configure ETA |
| NUMBER OF PERSON | Set number of persons |
| BLUE SIGN SET. | Set Blue sign settings |
| REPORT RATE SET. | Set report rate settings |

| TRANSCIVER (Setting for AIS receiving and sending) | |
|---|--|
| AIS TX | Transceiver status: turn on or off AIS message transmitting |
| DSC RX | DSC Monitor: turn on or off DSC monitoring function |
| GPS ANT. VOLTAGE | GPS antenna feeding voltage: set to 3.3V or 5V Note:- Antenna supplied with unit is a 3.3V unit |
| SYSTEM CONFIGURATION | |
| CUSTOMIZE | Personalization settings |
| RADAR VIEW | Radar configuration |
| MAP CALIBRATION | Map offset setting |
| SENSOR CONFIG. | Port configuration |
| FACTORY | Default factory setting |
| PASSWORD | Password change (default password: 0000) |
| LONG RANGE SET. | Remote inquiry setting |
| LR BCST SET. | Enable/Disable Long Range Broadcast |
| DEST TABLE SET. | Table storing destinations |
| ALARM SETTING | Configure ALR sentence status (Enable/Disable) |
| VSWR SETTING | VSWR setting |
| DIAGNOSTICS | |
| SYSTEM ON/OFF | Device activated log |
| MEMORY TEST | Memory test |
| SENSOR PORT | Transmission port test |
| TFT-PANEL | Screen panel |
| KEYBOARD TEST | Button test |
| GPS STATUS | GPS positioning status |
| TRANSCIVER | Transponder status |
| COMMUN. TEST | Test communication |
| PANEL TEST | Test Panel |
| VERSION | Firmware version |

Messages

The transponder features SRM alert pop-ups that can appear any time during operation. When a SRM (Safety Related Messages) from other AIS equipped vessels is received, you can either read and acknowledge it by pressing the knob or ignore the message by press ESC. If there is any unread message, the upper left corner will display , the new message icon. An example of a pop-up SRM message is shown below.

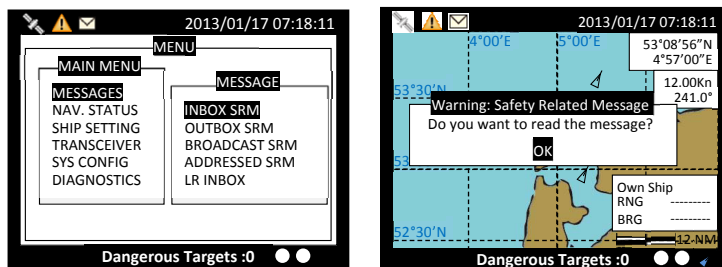

Message and SRM pop-up alert

Inbox SRM

You can read received SRM messages under Inbox. Turn the knob to traverse the message list and highlight your choice. Read the message content by pressing the knob.

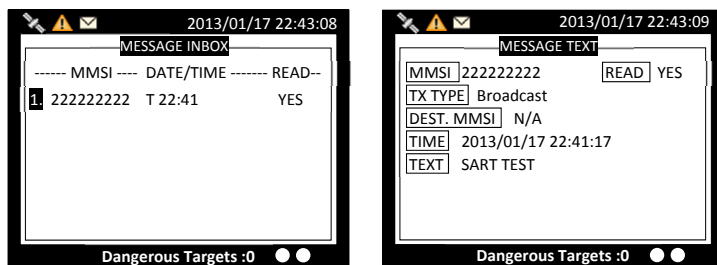

Received message list and message details

When pressing the FUNC button, system will ask whether the highlighted message should be deleted. Press knob to confirm your choice.

Outbox SRM

You can read all sent SRM messages under OUTBOX. Turn the knob to traverse the message list and highlight your choice. Read the message content by pressing the knob.



Sent message list and message details

When pressing the FUNC button, system will ask whether the highlighted message should be deleted. Press knob to confirm your choice.

When an addressed message is sent, the addressee will return an acknowledgement upon receipt of the message. The received acknowledgement is shown as "Y" in above example.

Broadcast SRM

This submenu allows the users to compose a Safety Related Message (SRM). Maximum length for the message is 90 characters. TRANSMIT CHANNEL gives you the option to send the message through channel A, B or Alternate. By Alternate, which is the default option, the system will select the channel automatically.

Press the knob to enter text input mode, then use the knob to enter text. When text editing is finished, press ESC to leave the text input mode.

To send the message, press MENU or ESC and the system will ask whether to send the message. Select OK to send, CANCEL to cancel and return to main menu.

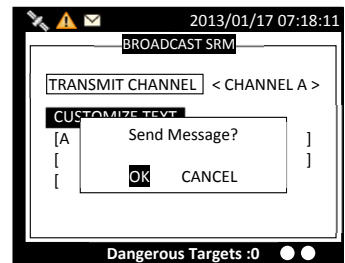
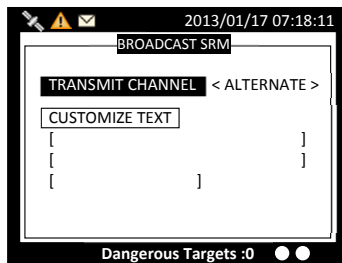

Edit and send Broadcast SRM

Addressed SRM

ADDRESSED SRM means a SRM addressed to a certain MMSI number which can be selected from the target list or input manually. By entering into the submenu "ADDRESSED SRM", users will be prompted to select the addressee from the target list. Here you can either pick the addressee or press ESC to leave the target list and enter the MMSI number manually.

Press the FUNC button and you have the possibility to add the selected vessel to your friend list, or to sort the list by MMSI, range or bearing. Please refer to page 5051 for more details.

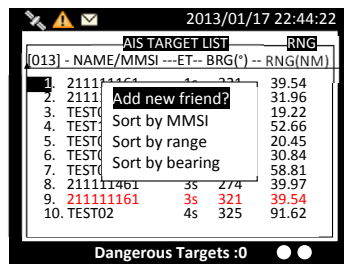
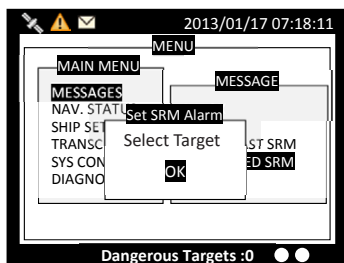

Addressed SRM

After entering the MMSI number, choose the transmit channel as described in page 43, then compose the message. Maximum length for the message is 85 characters.

To send the message, press MENU or ESC and the system will ask whether to send the message. Select OK to send, CANCEL to cancel and return to main menu.

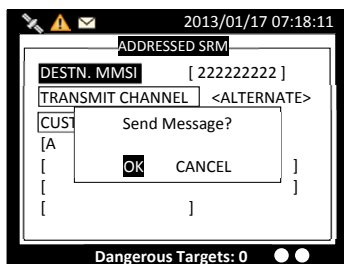

Send message

Long range message inbox

When the transponder is connected to a long range communication system via the long range communication port then long range interrogations may be received. These are requests for information from a distant base station beyond normal AIS

operation range. LONG RANGE MESSAGE INBOX holds all received Long Range Interrogation messages.

Turn the knob to traverse the message list.

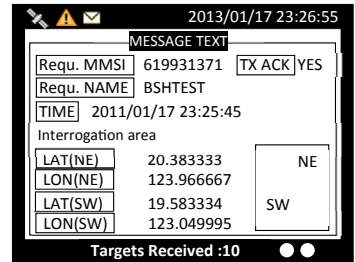
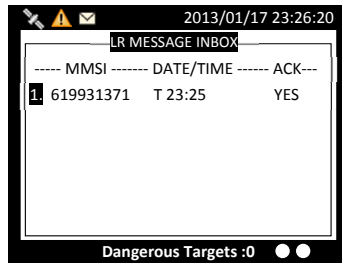

Long range message box

Turn the knob to traverse the message list and highlight your choice. Read the message content by pressing the knob.

When pressing the FUNC button, system will ask whether the highlighted message should be deleted. Press knob to confirm your choice.

Inland messages

The transponder has capability to send Inland ETA (Estimated Time of Arrival) messages and receive Inland RTA (Recommended Time of Arrival) messages which are used when communicating with ports, locks and bridges on the inland water ways. Note that the menu is only available when the unit is operating under inland mode.

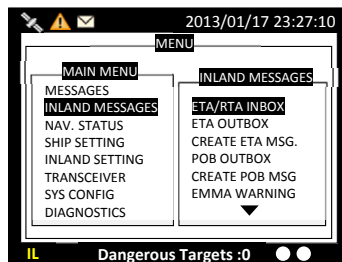

Inland message

ETA/RTA inbox

The received messages of ETA (RFM21) and RTA (RFM22) can be read in the ETA/RTA Inbox. Turn the knob to traverse the message list and highlight your choice. Read the message content by pressing the knob.

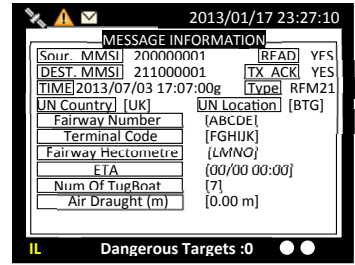
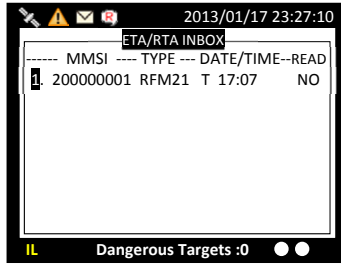

ETA/RTA inbox and message information

ETA outbox

The submenu displays log of sent ETA (RFM21) messages. Turn the knob to traverse the message list and highlight your choice. Read the message content by pressing the knob.

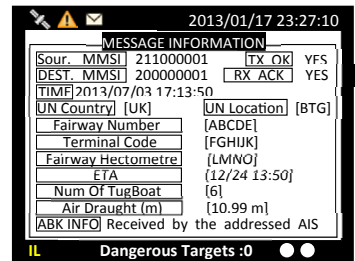

ETA outbox and message information

Create ETA message

For more information about ETA settings, please refer to page 6767.

In this submenu users can compose ETA (RFM21) message. By entering into the submenu, users will be prompted to select the addressee from the target list. Here you can either pick the addressee from the list or press ESC to leave the target list and enter the MMSI number manually.

TX CHANNEL gives you the option to send the message through channel A, B or Alternate. By Alternate, which is the default option, the system will select the channel automatically.

After ETA (RFM21) transmitted, if no RTA (RFM22) is received within 15 minutes, transponder will transmit ETA (RFM21).

After the addressee is selected, you can configure the ETA message.

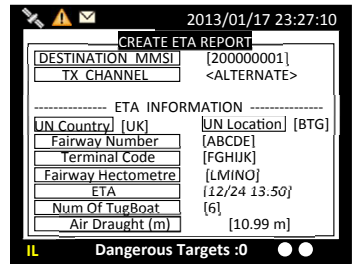
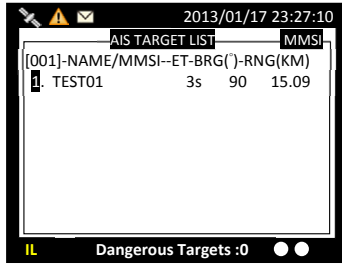

Target selection and ETA report

Use the knob to select a message and press it to display content.

POB outbox

The submenu displays log of sent Number of person on board (RFM55/IFM16) messages. The IMO version sends the total number of persons on board as a binary message with international IFM16. The Inland (IWW) version sends a message with number of crew, personnel and passengers as a binary message with inland branch RFM55.

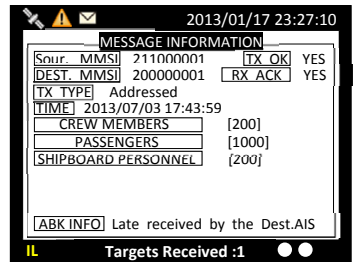

POB outbox and POB message information

Use the knob to select a message and press the knob to display message content.

Create POB message

In this submenu users can compose number of person on board (RFM55/IFM16) messages. Number of person onboard can be configured in Inland Setting 0.

By entering into the submenu, users will be prompted to select the addressee from the target list. Here you can either pick the addressee from the list or press ESC to leave the target list to enter the MMSI number manually or broadcast the POB message without specifying any addressee.

When "Broadcast" is selected, just omit the DESTINATION MMSI. Any entered number will be ignored.

The DATA TYPE provides the option either to send the data in RFM16 or RFM55, as described in page 47.

Tx CHANNEL gives you the option to send the message through channel A, B or Alternate. By Alternate, which is the default option, the system will select the channel automatically.

After ETA (RFM21) transmitted, if no RTA(RFM22) is received within 15 minutes, transponder will transmit ETA(RFM21).

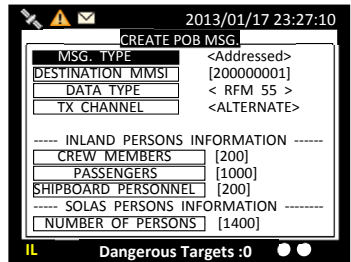

Target list and POB message content

EMMA warning

The submenu displays log of EMMA warning (RFM23) messages. EMMA (European Multiservice Meteorological Awareness system) Information is transmitted as broadcast message from shore to ship as local weather warnings.

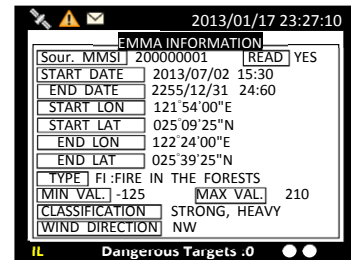
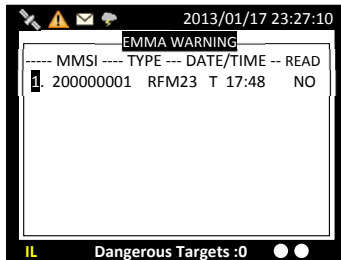

EMMA warning log and message content

Use the knob to select a message and press the knob to display message content.

Water level

This submenu displays received water level (RFM24) messages from base station to ship about local water level information.

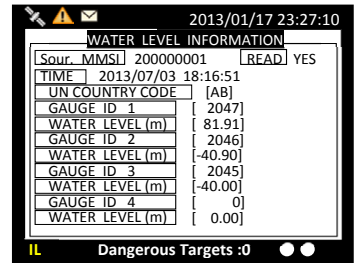
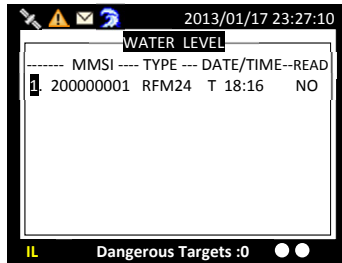

Water level log and message content

Use the knob to select a message and press the knob to display message content.

Navigation status

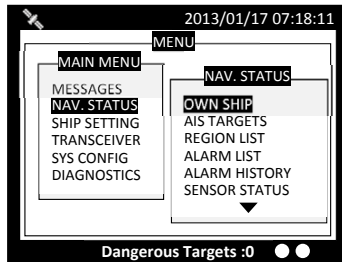

Own ship

This option displays the full information on your ship, including both dynamic and static data.

Turn the knob to change between dynamic and static information.

Static data and dynamic data

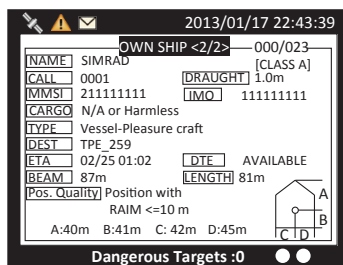
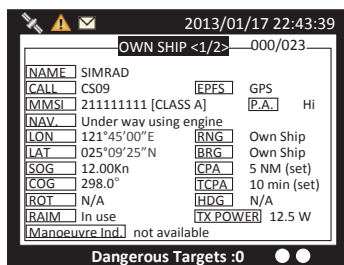

Static data and dynamic data

Inland vessel information

The following information is only available under inland mode.

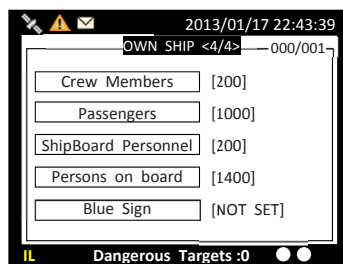
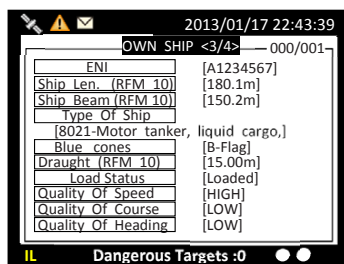

Additional inland vessel information

AIS targets

This option displays all received AIS information of other vessels including dynamic and static information. Press the knob to select an AIS target and then press the knob to go through dynamic and static information of the selected vessel. There are two pages of ship details for SOLAS mode and another two pages for inland mode.

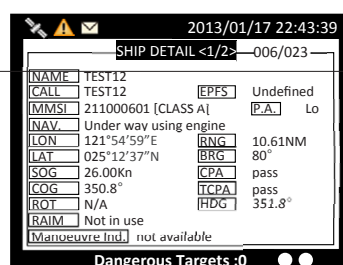
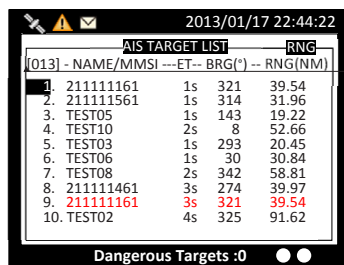

AIS targets and details

Turn the knob to continue reading the dynamic and static information of the selected vessel.

Additional inland information is available under inland mode.

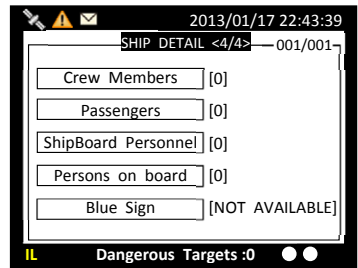
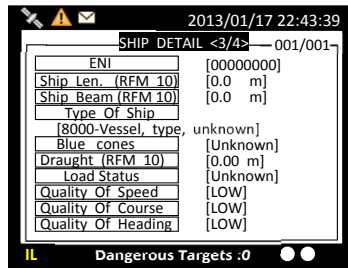

Ship's inland information



Adding friend ship

In the list, press FUNC button will open the pop-up window with the question whether the selected vessel should be added to your FRIEND SHIP list, or to sort the list according to vessels' MMSI, distance, or direction.



Adding friend ship

In the screenshot above, block A indicates the current sorting method.

| | |
|---|----------------------------------|
|  | By MMSI, in ascending order |
|  | By direction, in ascending order |
|  | By distance, in ascending order |

Region list

The region list displays all saved region areas. Turn the knob to traverse the list. Press the knob enables you to read the highlighted region information.

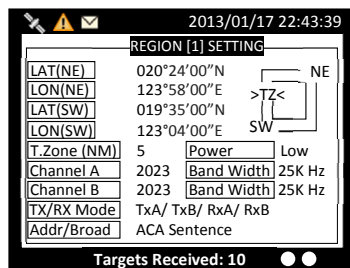

Region list and region setting

Editing existing region content

You can modify the region area setting by pressing FUNC button at the region information page. Use the scroll wheel to scroll to the field to edit, then press the knob to enter the value.

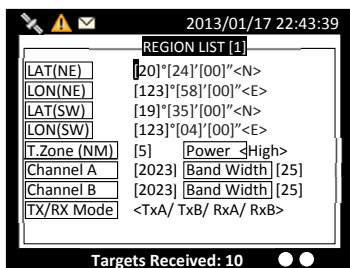
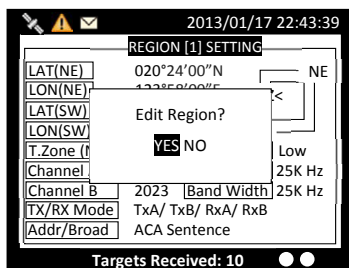



Modify region content

To save the settings, press MENU or ESC and the system will ask whether the changes should be saved. Select OK to save or CANCEL to discard and return to main menu. If the region information is unchangeable, saving does not change the original information.

Active alert

There are 2 ways to access the Active Alert: either through Main Menu/Navigation Status/Active Alert or with the hot key by holding the ESC key for 3 seconds and the unit will enter the Active Alert screen.

The list on screen shows all current AIS alerts and their status. Use the scroll wheel to navigate the list. You can acknowledge (ACK) the warning (priority: W). The system will ask for confirmation if the chosen alert should be acknowledged. If the alert active, an indication icon  will appear on left upper corner. If the warning “active – unacknowledged” activated, icon  will be flashing till all acknowledgement are made.

The display priority order, in sequence with the newest alert on top within each display priority, is:

1. “active – unacknowledged” and “active silenced” warnings
2. “rectified – unacknowledged” warnings
3. “active – acknowledged” warnings
4. “active” cautions.

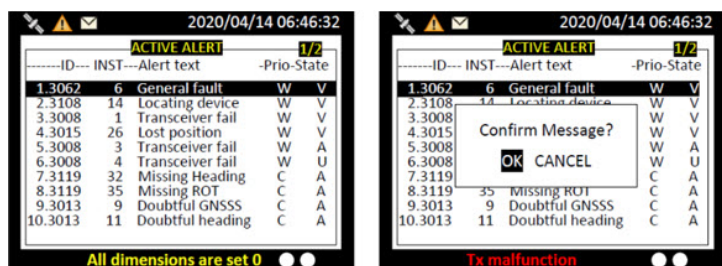

Alert list (BAM) and acknowledgement

Table – BAM alert instance

| Alert ID | Alert text | Additional information | Prio | Cat | Escal | BIIT ID |
|----------|------------------|-----------------------------------|------|-----|-------|---------|
| 3108 | Locating device | Check AIS targets | W | B | W | 14 |
| 3062 | General fault | Check AIS equipment | W | B | W | 6 |
| 3008 | Transceiver fail | Not transmitting, check AIS | W | B | W | 1 |
| | | Not receiving, check AIS | W | B | W | 3`4 |
| 3015 | Lost position | Own ship position not transmitted | W | B | W | 26 |

| | | | | | | |
|------|------------------|--|---|---|--|----|
| 3116 | Impaired radio | Reduced coverage (antenna VSWR) | C | B | | 2 |
| | | Ch1 inoperative, check AIS | C | B | | 3 |
| | | Ch2 inoperative, check AIS | C | B | | 4 |
| | | DSC inoperative | C | B | | 5 |
| 3113 | Sync in fallback | Check AIS for UTC time synchronisation | C | B | | 7 |
| 3003 | Lost ext EPFS | Check external position sensor | C | B | | 25 |
| 3119 | Missing COG | Not transmitting COG | C | B | | 30 |
| | Missing SOG | Not transmitting SOG | C | B | | 29 |
| | Missing heading | Not transmitting heading | C | B | | 32 |
| | Missing ROT | Not transmitting rate of turn | C | B | | 35 |
| 3013 | Doubtful GNSS | Int/Ext GNSS position mismatch | C | B | | 9 |
| | Doubtful heading | Difference with COG exceeds limit | C | B | | 11 |
| 3019 | Wrong NavStatus | Check NavStatus setting | C | B | | 10 |
| 3009 | Lost MKD | Cannot display safety-related messages | C | B | | 8 |

Note 1, Alert priority (Prio): W (Warning) ` C (Caution) °

Table - Alert state and audible annunciation for warnings

| Alert state | Audible annunciation |
|-------------------------------|---|
| V: active – unacknowledged | 2 short audible signals and repeated as a warning after 3 minutes |
| S: active – silenced | None |
| A: active – acknowledged | None |
| U: rectified – unacknowledged | None |

Table - Alert state and audible annunciation for cautions

| Alert state | Audible annunciation |
|-------------|----------------------|
| A: active | None |

V5035 features SART/MOB (locating device) alert that can appear any time during operation. When SART/MOB message is received, the  icon will appear in the status bar with beeping sounds from the beeper. Press any button to stop the sound.

An example of an alert message is shown below.

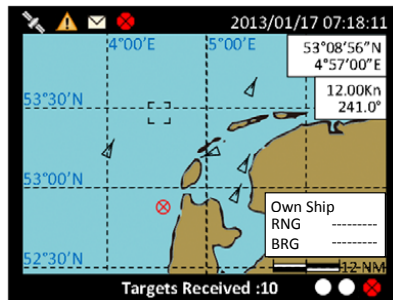

SART/MOB message alert

Active BIIT list

The list on screen shows all current device alerts and their status. Use the scroll wheel to navigate the list.

You can acknowledge (ACK) the alert message either by pressing FUNC or by pressing the knob. The system will ask for confirmation if the chosen alert should be acknowledged.

The transponder performs a function self-check continuously. If a self-check fails, an alert will occur. Appendix B shows all possible alert scenarios.

However, the following 5 alerts require the user's immediate attention and will be displayed directly on the Transmission and Reception Bar:

- Tx malfunction: transmission function fails
- Antenna VSWR exceeds limit
- NavStatus incorrect: wrong NavStatus
- Improper MMSI: no valid MMSI
- GPS antenna port shorted

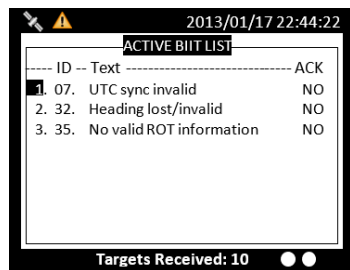

Active BIIT list and acknowledgement

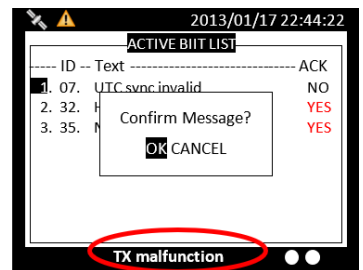

BIIT history

This submenu lists all recorded BIIT alert and its time of occurrences.

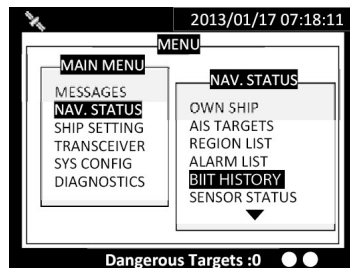

BIIT history

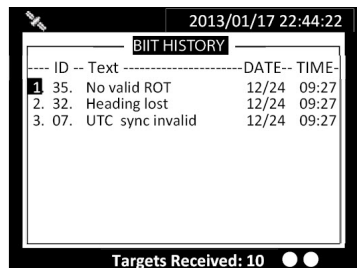

Sensor status

Display sensor statuses:

| Sensor | Status |
|------------------|--|
| POSITION STATUS | EXT. DGNSS / INT. DGNSS MSG.17 / EXT. GNSS / INT. GNSS / NO GPS |
| POSITION QUALITY | No position Manual position Dead reckoning position valid position with no time stamp Position > 10m Position with RAIM > 10 m Position <= 10 m Position with RAIM <= 10 m Outdated position > 200 m |
| UTC STATUS | VALID / LOST (Note 1) |
| COG STATUS | INT. COG / EXT. COG / LOST |
| SOG STATUS | INT. SOG / EXT. SOG / LOST |
| HEADING STATUS | VALID / LOST |
| ROT STATUS | VALID / OTHER ROT / LOST |

Note 1: If V5035 not connect internal GPS, will lost UTC and time is unsynchronized. V5035 will continue operation using indirect or semaphore synchronization.

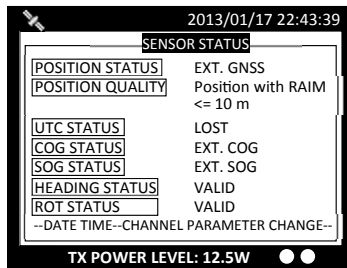

Sensor status

Dangerous list

With the setup of closest point of approach (CPA) and time to CPA (TCPA) (refer to page 63), this submenu provides an efficient way to monitor vessels with insufficient CPA and TCPA. The dangerous targets can also be observed on coastal and radar view.

Turn the scroll wheel to navigate the list and press the knob to read information of the selected vessel. Turn the knob again to go the second page for more details.

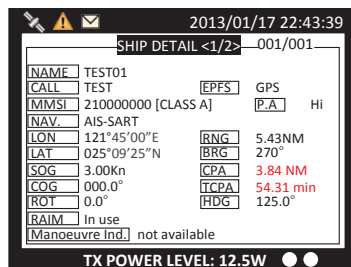
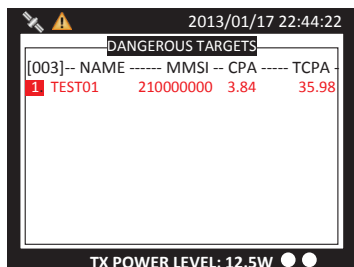

Dangerous list and vessel details

MOB list

With the setup of MOB list, MOB can be easily traced by the person's name not just by the MMSI number on the MOB device.

This submenu enables adding, removing, or modifying of MOB list entries.

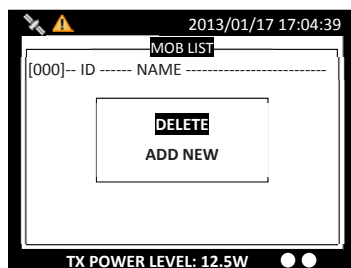
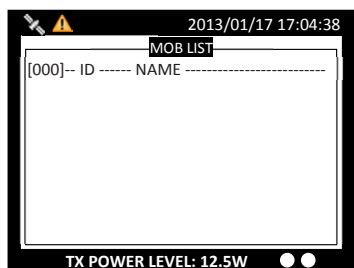

In the list, press FUNC button will open the pop-up window with the question whether the selected entry should be deleted, or to add a new entry to the list. After MMSI number and name are assigned, press MENU or ESC to save or leave without saving. The existing entry can be modified by pressing the knob to enter the text edit mode. Use the knob to edit the list and press MENU or ESC to save or leave without saving.

Friend ships

The users can easily recognize the friend ships on coastal view and radar view, when the list of friend ships is set up. This submenu allows you to add, delete and edit the list of all registered friend ships.

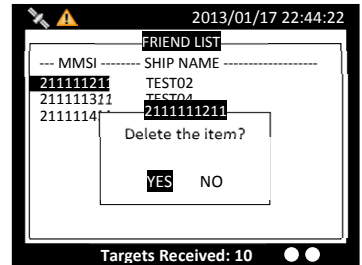
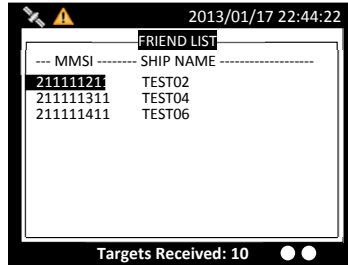

List of friend ships

In the list, press FUNC button will open the pop-up window with the question whether the selected vessel should be deleted. After MMSI number and name are assigned, press MENU or ESC to save or leave without saving.

The existing entry can be modified by pressing the knob to enter the text edit mode. Use the knob to edit the list and press MENU or ESC to save or leave without saving.

Ship setting

This menu list provides access to settings that are required during installation of the transponder. There are a total of 5 submenus.

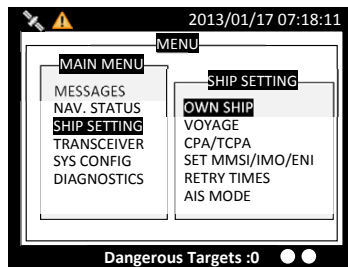

Own ship

This section is password protected and can only be accessed using the password (page 72).

The following information about the vessel should be correctly set up by installation prior to operation:

- Call Sign - Vessel radio call sign (limited to 7 characters)
- Ship Name - limited to 20 characters
- Position of internal GPS antenna - giving the location of the GNSS antenna connected to the AIS transceiver (Internal GPS)
- Position of external GPS antenna - giving the location of the GNSS antenna connected to any external position source connected to the AIS transceiver
- Length and Beam – measured length and width of the ship (inland mode only)

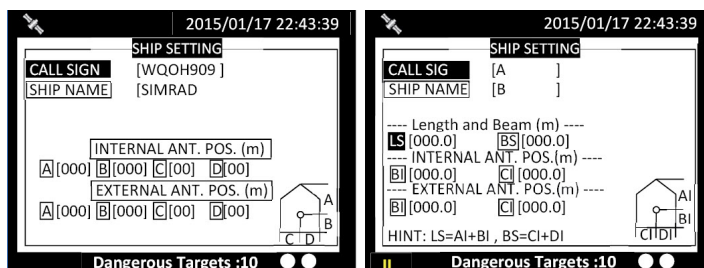

Ship setting in SOLAS mode (left) and inland mode (right)

Voyage

SOLAS mode

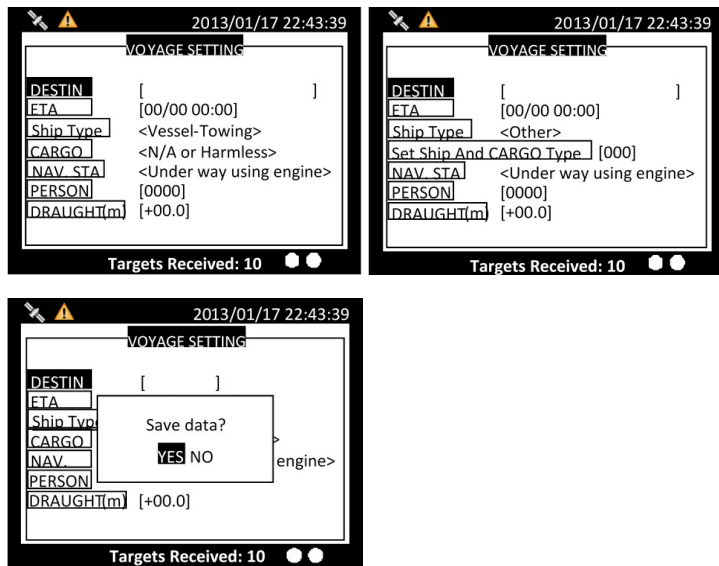

SOLAS voyage setting

In this submenu the following navigational information can be configured:

- Destination – Ship's next destination port (limited to 20 characters). When destinations are defined in "Destination Table Setting" (see page 74), user can set the Destination by clicking on FUNC button. Each time when the FUNC button is pressed, the Destination displayed will rotate in the order from Column 1 to Column 10 as configured in the table.
- ETA – Estimated time/date of arrival at destination (UTC time).
- Ship Type – use the scroll wheel to select the type of vessel from the list.
- Cargo – use the scroll wheel to select the suitable status from the list. When "Other" of Ship Type setting is selected, **Set Ship And CARGO Type** will show up on screen instead of CARGO, user can enter a pre-defined number of "Ship And CARGO Type" into it.
- Navigational status – use the scroll wheel to select the suitable status from the list.

- Person – the number of people on board.
- Draught – Maximum present static draught to the nearest 1/10th of a meter.

To save the settings, press MENU or ESC and the system will ask whether the changes should be saved. Select OK to save or CANCEL to discard and return to main menu.

➔ **Note:** If Ship Type is Tanker, by regulation, whenever the ship navigation status is “Moored”, the transponder’s transmission power is automatically changed to 1W for safety measures.

Inland mode

Under inland mode, voyage configuration does not include PERSON setting. To set up number of person on board, please go to INLAND SETTING/NUMBER OF PERSON.

By CONVOY EXTENSION, the dimensions of the vessel are set to the maximum rectangular size of the convoy when operating in inland AIS mode.

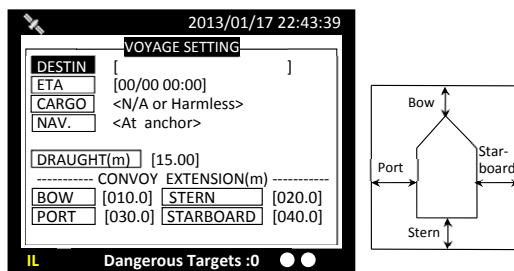

Inland voyage setting

CPA/TCPA

In this submenu the closest point of approach (CPA) and time to CPA (TCPA) can be set. The vessels with insufficient CPA and TCPA will be displayed in the dangerous list (page 58) and on coastal and radar view.

- CPA – in nautical miles
- TCPA – in minutes
- Alarm – when alarm is connected to the transponder via junction box, you can choose whether alarm should be activated when a dangerous target appears.

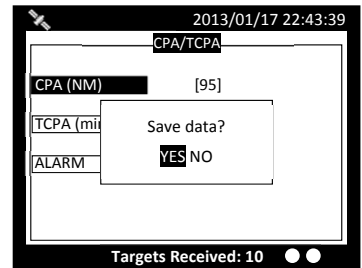
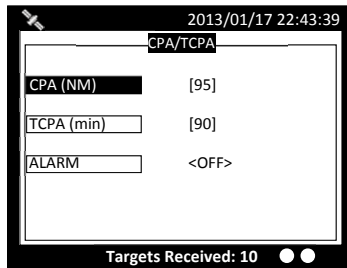

CPA/TCPA

To save the settings, press MENU or ESC and the system will ask whether the changes should be saved. Select OK to save or CANCEL to discard and return to main menu.

Extended tow dimension values

It is beneficial to navigation safety for the true dimensions of vessels to be available via AIS Message 5. Currently, the ABCD values in Message 5 are difficult to change once set, requiring a password that may not be available to the vessel navigator.

This is not a problem for most vessels, except those engaged in towing operations by pushing ahead or alongside (navigational status is 12). In these instances, it may be desirable to provide easier access to and modification of vessel dimension values.

When navigational status is 12, user can set extended tow dimension values on this page.

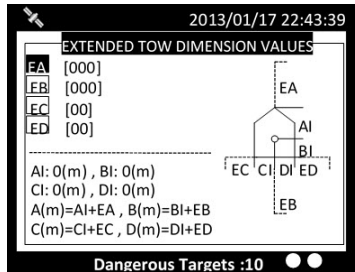

Extended tow dimension values

Set MMSI/IMO/ENI

This section is password protected and can only be accessed using the password (page 72).

SOLAS mode

This submenu provides access to set MMSI and IMO. Use the knob to choose the menu option either MMSI or IMO.

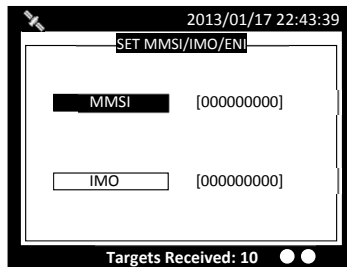

Set MMSI/IMO/ENI

For SOLAS vessels, the MMSI number can be entered in a valid range which is indicated on the input screen.

To save the settings, press MENU or ESC and the system will ask whether the changes should be saved. Select OK to save or CANCEL to discard and return to main menu.

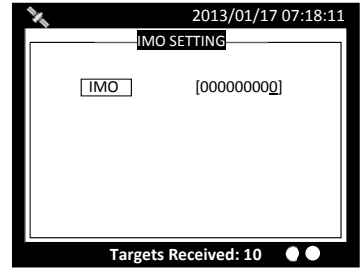
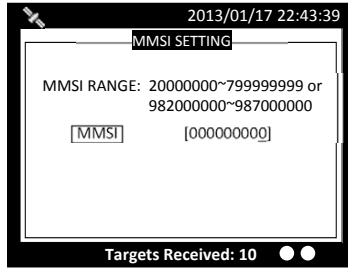

MMSI/IMO setting

Inland mode

The ENI (unique European Vessel Identification Number) setting is only available under inland mode, while IMO setting is not accessible in this mode. The procedure to set/change MMSI number is same as described in “SOLAS mode” on page 64.

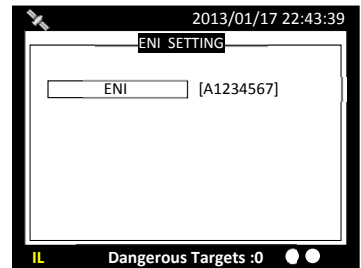
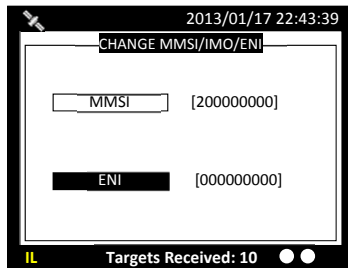

ENI setting

→ **Note:** When setting is done, press ESC to exit.

Retry times

In order to resend messages when the transmitted Message 6 or Message 12 receives no acknowledgement of Message 7 or Message 13, you can set how many times you want the system to resend messages. The options are 0 (no repeat), 1 (repeat one time), 2 (repeat 2 times) or 3 (repeat 3 times).

AIS mode

Here you can configure the transponder to operate in SOLAS or INLAND mode. Each mode has some specific submenu and menu options.

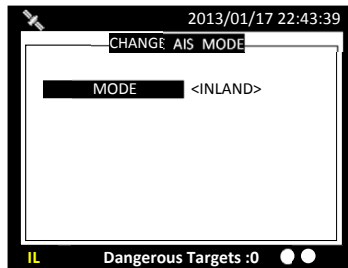

Switching between SOLAS and inland modes

Inland setting

All boat information inland setting can be found under this menu.

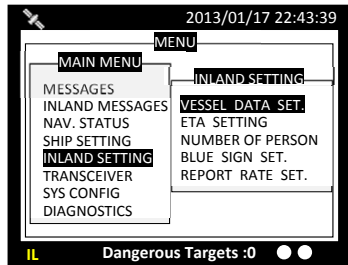

Submenus under inland setting

Vessel data setting

Inland related vessel data can be set in this submenu:

- ERI Ship Type – ERI classification code.
- Blue Cones - The number of blue cones or blue flag status for the cargo (1, 2 or 3 blue cones, or blue flag).
- Load Status - 'Loaded', 'Unloaded', 'Unknown'
- Quality of Speed, Course and heading information - will be shown as 'high' when the target vessel is using an approved sensor to generate this data, or low if the data is derived from internal GNSS only.



Inland related vessel data

ETA setting

This menu provides ETA (RFM21) related setting:

- UN country and location code - the voyage destination should be entered using UN country (2 characters) and location codes (3 characters) where possible.
- Fairway Number, Terminal Code & Fairway Hectometre: each is limited to 5 characters when available
- ETA - Estimated time / date of arrival at destination (using UTC time)
- Number of Tugboats: The number of assisting tugboats (from 0 to 6 or unknown)
- Air Draught: The air draught of the vessel to the nearest centimeter.

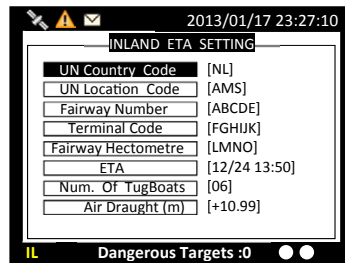

Inland ETA setting

To save the settings, press MENU or ESC and the system will ask whether the changes should be saved. Select OK to save or CANCEL to discard and return to main menu.

Number of person

This submenu provides Number of Person (RFM55) setting:

The number of crew (0 to 254 or unknown), passengers (0 to 8190 or unknown) and other shipboard personnel (0 to 254 or unknown).

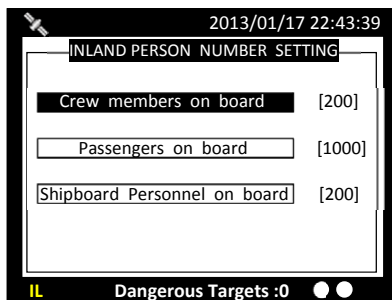

Number of person setting

Blue sign setting

Blue Sign information helps you recognize the approaching vessels in your inland waterway area. A 'blue sign' switch may optionally be connected to the AIS transceiver during installation. This setting enables or disables the blue sign switch on the Junction Box.

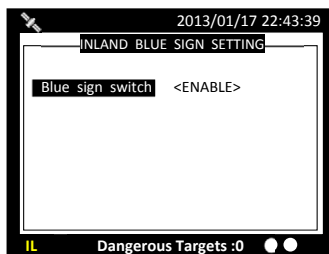

Blue sign switch setting

Report rate setting

Set V5035's report rate. Selectable report rates are AUTO/ 10 SEC./ 5 SEC./ 2 SEC.

Transceiver

This section is password protected and can only be accessed using the password (page 72). The submenu allows the users to switch on or off the transmission and change the supplied voltage of the GPS antenna between 3.3V and 5V. It also enables to switch the transmission power between 12.5W, as "normal", and 1W.

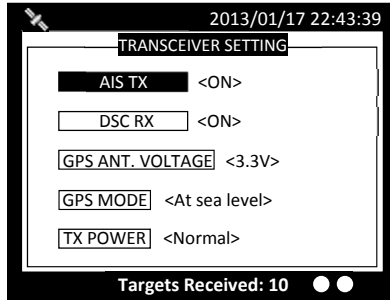

For inland vessels that operate at altitude higher than 500 meters, the transponder needs GPS Mode set to “Altitude higher than 500m” for better GPS positioning performance. To save the settings, press MENU or ESC and the system will ask whether the changes should be saved. Select OK to save or CANCEL to discard and return to main menu.

System configuration

System configuration provides access to user configurable preferences for V5035. All user settings are stored within the transponder and are maintained if the power supply is switched off. After the setting is done, press MENU or ESC and the system will ask whether the changes should be saved. Select OK to save or CANCEL to discard and return to main menu.

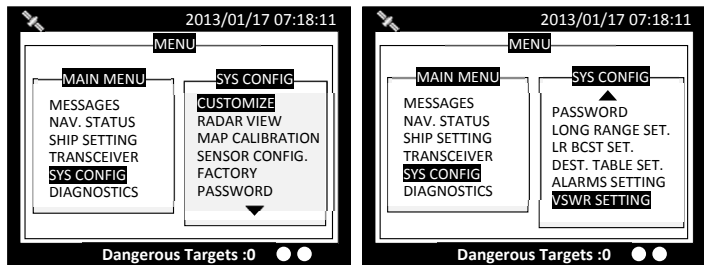

System configuration

Customize

Customize provides personalization settings:

- Dimmer Level - brightness setting from 1 (low) to 100 (high)
- Colour mode - brightness and contrast adjustment for the LCD display along with selection of day or night operating mode. In night mode the display colours are inverted (light text on a dark background).

- Key time-out - time to leave menu screen and switch back to coastal view
- Language - available: select the user interface language from the available language options.
- Key Beep – turn on or off the key beep
- Time Zone – set the time zone
- SART test mode – hide or display the SART test message
- NMEA 2000 device instance is used to identify multiple similar products connected on the same NMEA 2000 network. The setting value is between 000 and 252.
- Coordinate Format – user can choose between DD°MM'SS" (degrees, minutes, seconds) and DD°MM.mm' (degrees, minutes, decimal minutes) to display the vessel coordinate.

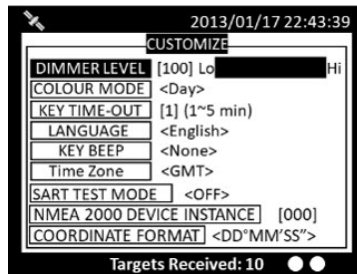

Customize

Radar view

This setting provides user the ability to center the radar map on given coordinates.

Turn knob to choose either latitude or longitude and press knob to confirm. Once pressed, turn knob to choose a parameter and press knob again to enter input mode. When finished, press ESC to return to the level before. Continue these procedures till all settings are set.

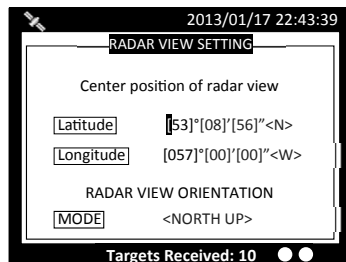

Radar view setting

In this view setting, RADAR VIEW ORIENTATION has NORTH UP/ COURSE UP / HEAD UP view modes.

Map calibration

This setting offers user functions to calibrate map data. Turn knob to select either latitude or longitude to offset. Press knob to enter input mode. Turn knob to select an offset value. Once finished press ESC to return to the previous level to continue the setting.

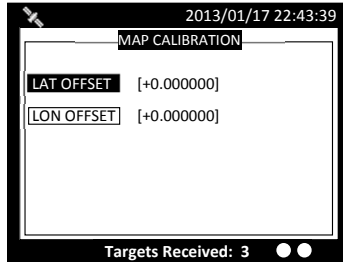

Map calibration

Sensor configuration

This section is password protected and can only be accessed using the password (page 72).

Sensor Configuration provides user to set baud rates for sensor ports and USB port. Turn knob to select a port to modify and press knob to change the specified port baud rate. Turn knob to change the desired rate of sensor ports between 4800/9600/19200/38400. USB port can be configured to any baud rate of 4800/9600/19200/38400/57600 or 115200. Default baud rates of the ports are shown in below example.

When finished, press knob again to return to the previous level.

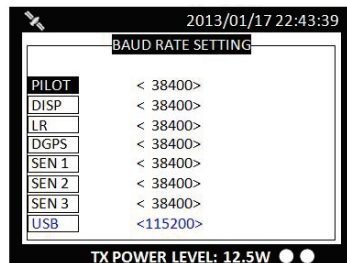

Baud rate setting

Factory

This section is password protected and can only be accessed using the password (page 72).

Press knob to confirm your choice and the following settings will be restored to their original value: MOB/Friend ship List, destination list, time zone, language, dimmer, CPA/TCPA and system password.

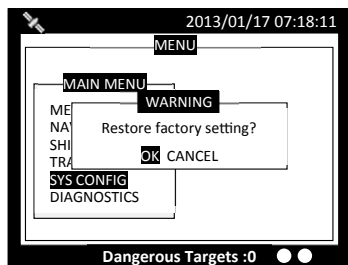

Factory setting

Password

This submenu enables users to change user password. Certain important information stored within the transponder can only be changed with the password. Password is required for the access of the following sections:

- Own Ship (page 4960) – contains information about call sign, vessel name and ship type
- Set MMSI/IMO/ENI (page 64) – contains information about MMSI and IMO number
- Transceiver (page 68) – enables the option to activate/deactivate AIS transmission
- Sensor Configuration (page 7169) – about baud rate configuration of sensors
- Factory (page 7271) – restoration of factory setting
- Alarms Setting (page 7474)
- VSWR Setting (page 7474)

 (Default password: "0000")

Use the knob in the order of "OLD PASSWORD", "NEW PASSWORD", "CONFIRM NEW PASSWORD". Repeat till all four values are entered.

To save the settings, press MENU or ESC and the system will ask whether the changes should be saved. Select OK to save or CANCEL to discard and return to main menu.



Long range setting

This option provides user choices to auto-respond remote interrogation and settings of the response information.

You can either set MODE to either AUTO or MANUAL. The setting for the rest of information is either SUPPLY or REJECT.

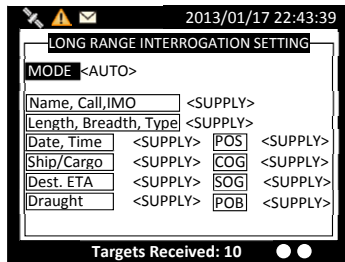

Long range broadcast

Class A transmits Message 27 every 3 minutes through the channels alternately. Provided here are the options to enable or disable Long Range Broadcast and the transmitting channel for Message 27.

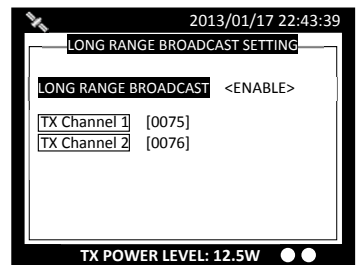
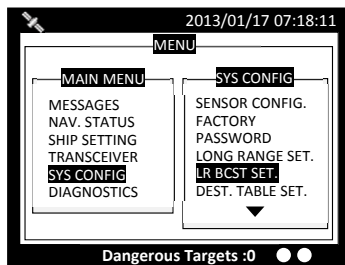

→ **Note:** Only AIS channel numbers can be entered for TX channel. Channel 2078, 2088, and the current channel used in the region cannot be used.

Destination table setting

Save up to 10 destinations. Use rotary knob to traverse text and to modify. Press Menu to save changes.

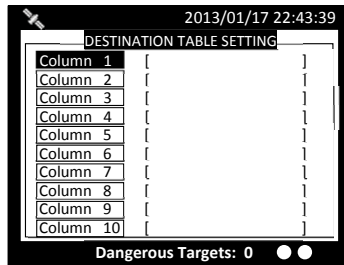

Alarm setting

This menu is password protected. The menu can be used to enable or disable ALR 25/32/35 sentence. For instance, if an ALR sentence is disabled, the corresponding alarm would not activate.

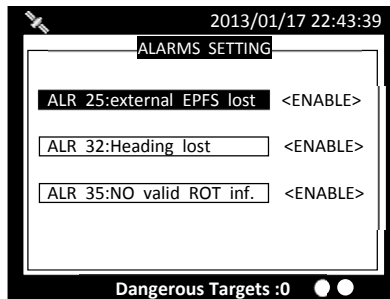

Alarm setting for ALR 25/32/35

VSWR setting

The VSWR setting function allows the fine-adjustment of VSWR threshold according to the cable length and VHF antenna characteristics. This function is password protected (page 72) and should be performed by a qualified service partner or dealer.

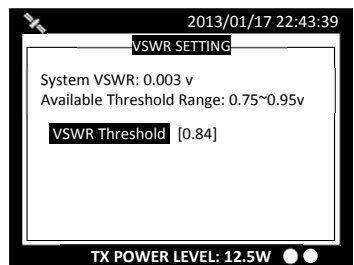
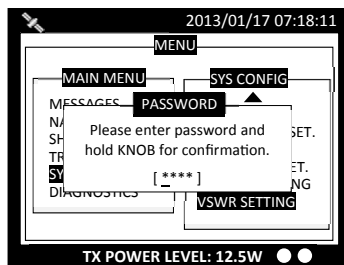

Diagnostics

This submenu provides users to check system statuses. There are a total of 8 check options.

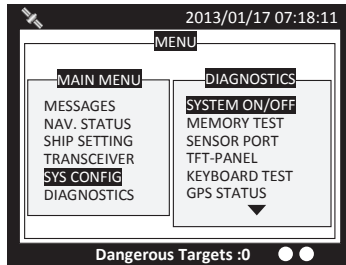

System On/Off: This option provides activation history (any power-off session less than 15 minutes would not be registered in the history).

Memory Test: This option provides memory testing on the unit.

Sensor Port: This option provides an overview of baud rates on all ports and status information.

TFT-Panel: This option provides color information on the monitor.

Keyboard Test: This option provides keyboard testing. Pressing button during testing, a corresponding button on the screen will response. After all buttons are tested, a message will indicate. Press knob for OK to exit. To quit test without completing, wait for 30 seconds and the system will return to the main menu.

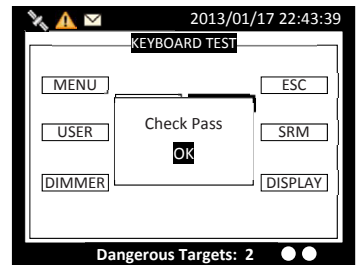
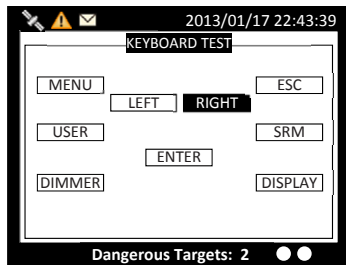

Keyboard test

GPS status: This option provides GPS satellite status information. Green indicates satellite being used for GPS fix. Red indicates satellite not being used.

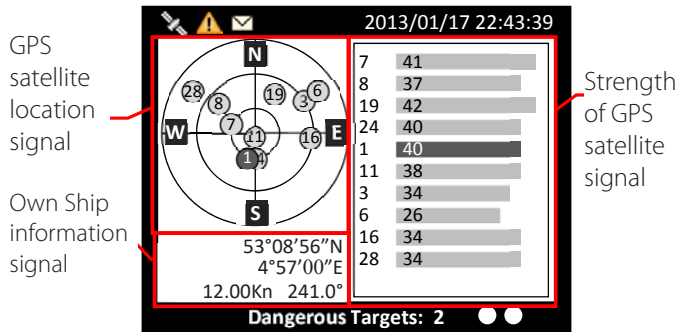

GPS status

Transceiver: This option allows the user to view the frequencies and status. When finished, press ESC to exit.

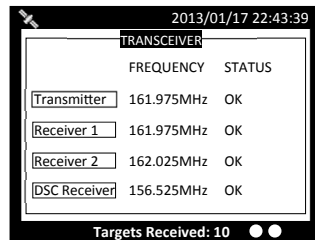

Transceiver

Communication Test: Communication can be tested. The procedure starts by transmitting Message 10 to an addressed Class A MMSI. The addressee MMSI, once received Message 10, will return Message 11. The test is then complete when the transponder successfully receives the Message 11.

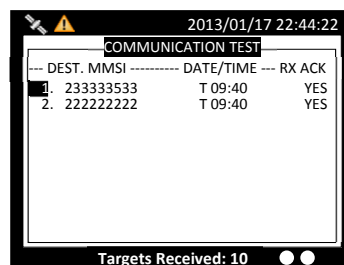

Communication test

Press the FUNC button to start the communication test. Follow the on-screen instruction to select a class A MMSI number. Then press MENU, ESC or FUNC and click "OK" to start the transmission of Message 10. Only Class A units with GPS fix are listed and eligible for communication testing.

The left screen below indicates no valid Class A targets found.

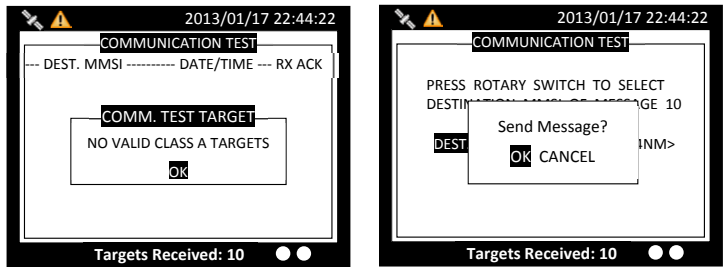

No valid targets

After pressing the knob, turn the knob to selected destination MMSI for testing. The destination MMSI numbers are the nearest Class A targets found close to the Class A unit. Press ESC or MENU to pick selection and the unit will prompt to confirm message sending. Select OK to proceed testing.

Panel test

In the submenu users can test the brightness of the screen.

Press "FUNC" to switch the white cube between different sizes.

Rotate the scroll wheel quickly to test different stages of brightness.

To exit the function, press "MENU" or "ESC".



Test with size and brightness

Version

Provide model name, hardware information, delivered firmware version on the unit, etc. When finished, press ESC to exit.

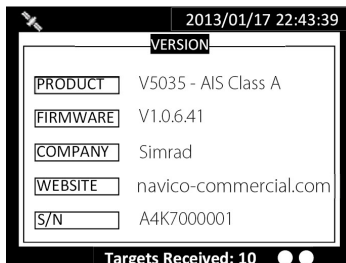

Version information

5

Technical specifications

Applicable standards

| | |
|--|--|
| IMO Resolution A694(17) | IEC 61993-2 Ed. 3.0, 2018 |
| IMO Resolution MSC.74(69) Annex 3 | IEC 61108-1 Ed. 2.0, 2003 |
| IMO Resolution MSC. 191(79) | IEC 60945 Ed. 4.0, 2002 incl. Corr. 1 2008 |
| ITU-R M 1371-5 (Class A), 2014 | IEC 61162-1 Ed. 5.0, 2016 |
| ITU-R M 825-3, 1998 | IEC 61162-2 Ed. 1.0, 1998 |
| ITU-R M 1084-5, 2012 | IEC 62288 Ed. 2.0, 2014 |
| CCNR test standard for Inland AIS, edition 2.0 (October 2012) | IEC 62923-1 Ed. 1.0, 2018 IEC 62923-2 Ed. 1.0, 2018 |

VHF transceiver

| | |
|---------------------------|----------------------------------|
| Frequency Range | 156.025 MHz ~ 162.025 MHz |
| Channel Bandwidth | 25 KHz |
| Modulation | GMSK / FM |
| Data Rate | 9,600 bps |
| Number of AIS Transmitter | 1 |
| Number of AIS Receiver | 2 |
| Number of DSC Receiver | 1 |
| AIS Channel 1 | CH 87B (161.975 MHz) |
| AIS Channel 2 | CH 88B (162.025 MHz) |
| Tx Power Output | 1/12.5 Watt (30/41 dBm ± 1.5 dB) |
| Rx Sensitivity | < -107 dBm @ 20% PER |

DSC receiver

| | |
|-----------------------------|---|
| Frequency | 156.525 MHz |
| Modulation | FSK |
| Channel Bandwidth | 25 KHz |
| Sensitivity | < -107 dBm @ BER < 10 ⁻² |
| Spurious Response Rejection | ≥ 70 dB for signal @ -104 dBm; BER ≤ 1 % |

| | |
|----------|---|
| Blocking | ≥ 84 dB for signal @ -104 dBm; BER ≤ 1 % |
|----------|---|

GPS receiver (internal)

| | |
|-----------------------------------|------------------------------------|
| Receiving Channels | 50 channels |
| Tracking & Navigation Sensitivity | ≥ -159 dBm |
| Reacquisition Sensitivity | ≥ -159 dBm |
| Horizontal Position | < 2.5 m Autonomous < 2.0 m SBAS |
| Receiver Type | SBAS: WAAS, EGNOS, MSAS, GAGAN |

Power supply

| | |
|-------------------|---|
| Supply Voltage | 12V / 24 V DC |
| Power Consumption | Less than 9 W average @ 12 V DC; Less than 65 W peak power @ 12 V DC |

LCD display

| | |
|---------------------------|--|
| Screen Size | 3.5" color TFT |
| Pixel Number (Resolution) | 320 x 240 |
| Viewing Mode | Basic coastline map/ Radar View/ Alphanumeric views /Satellite View |
| Dimmer Control | Step-less Setting |

Keypad and knob

| | |
|--------------------------|---|
| 6 keypads with backlight | 1 for SRM, 1 for Menu, 1 for Dimmer, 1 for ESC, 1 for Display, 1 for Nav. Status |
| Knob | Multi-Function |

Connection interface

| | |
|--------------------------|-------------------|
| GPS Antenna Connector | TNC (Female) |
| VHF Antenna Connector | SO-239 (Female) |
| Sensor Interfaces 1 to 3 | IEC 61162-1 or -2 |
| Pilot / Auxiliary | IEC 61162-2 |
| External Display | IEC 61162-2 |

| | |
|------------------------|---------------------------|
| Long-range | IEC 61162-2 |
| DGNSS correction input | RTCM-SC-104 |
| Alarm relay | Normally closed |
| USB | Mini type B USB interface |
| NMEA2000 | IEC61162-3 |
| Alarm Output | Relay contact |

Environmental

| | |
|-----------------------|--------------------------------|
| Operating Conditions | IEC 60945 "protected" category |
| Operating Temperature | -15°C ~ 55°C |
| Operating Humidity | 95% RH at 40°C |
| Waterproof | IPX2 |

Physical

| | |
|----------------------------|--------------------|
| Width | 205 mm (8.07 inch) |
| Height | 85 mm (3.34 inch) |
| Depth (include connectors) | 173 mm (6.81 inch) |
| Weight | ≤ 1.16 kg |

Pilot plug

| | |
|----------------|-------------------|
| Cable length | 2 m |
| Connector type | Std. Sex 206486-2 |

NMEA 2000 PGN information

This table lists NMEA 2000 messages supported by the V5035 unit. The "Transmit" PGNs information includes "Own ship" + "Received AIS information from other ships". This is the reason the NMEA2000 PGN list covers both Class A and Class B related information.

| Transmit | |
|----------|--|
| PGN | Description |
| 59392 | ISO Acknowledgment |
| 59904 | ISO Request |
| 60928 | ISO Address Claim |
| 126464 | PGN List - Transmit PGN's group function |
| 126996 | Product Information |

| | |
|--------|---|
| 129025 | Position Rapid Update |
| 129026 | COG SOG Rapid Update |
| 129029 | GNSS Position Data |
| 129038 | AIS Class A Position Report |
| 129039 | AIS Class B Position Report |
| 129040 | AIS Class B Extended Position Report |
| 129041 | AIS Aids to Navigation (AtoN) Report |
| 129539 | GNSS DOPs |
| 129540 | GNSS Sats in View |
| 129792 | AIS DGNSS Broadcast Binary Message |
| 129793 | AIS UTC and Date Report |
| 129794 | AIS Class A Static and Voyage Related Data |
| 129795 | AIS Addressed Binary Message |
| 129796 | AIS Acknowledge |
| 129797 | AIS Binary Broadcast Message |
| 129798 | AIS SAR Aircraft Position Report |
| 129800 | AIS UTC/Date Inquiry |
| 129801 | AIS Addressed Safety Related Message |
| 129802 | AIS Safety Related Broadcast Message |
| 129803 | AIS Interrogation |
| 129804 | AIS Assignment Mode Command |
| 129805 | AIS Data Link Management Message |
| 129806 | AIS Channel Management |
| 129807 | AIS Group Assignment |
| 129808 | DSC Call Information |
| 129809 | AIS Class B "CS" Static Data Report, Part A |
| 129810 | AIS Class B "CS" Static Data Report, Part B |

Receive

| PGN | Description |
|--------|--------------------|
| 59392 | ISO Acknowledgment |
| 59904 | ISO Request |
| 60928 | ISO Address Claim |
| 127250 | Vessel Heading |
| 127258 | Magnetic Variation |

6

Mechanical dimensions

V5035 transponder main unit

Front (size: mm)

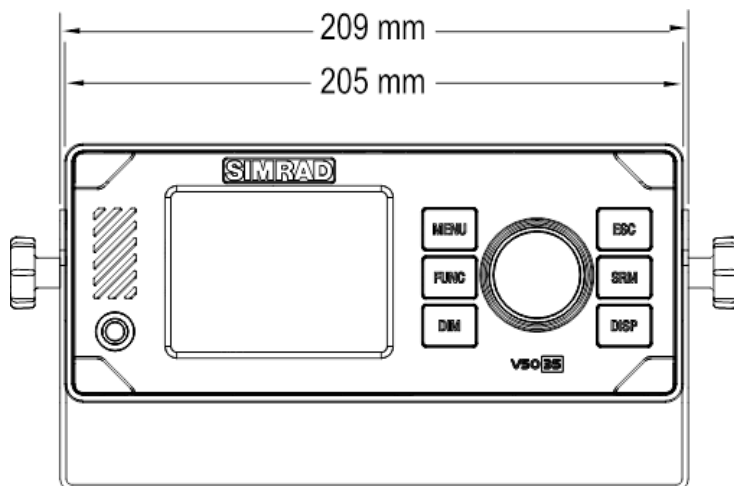

Side (size: mm)

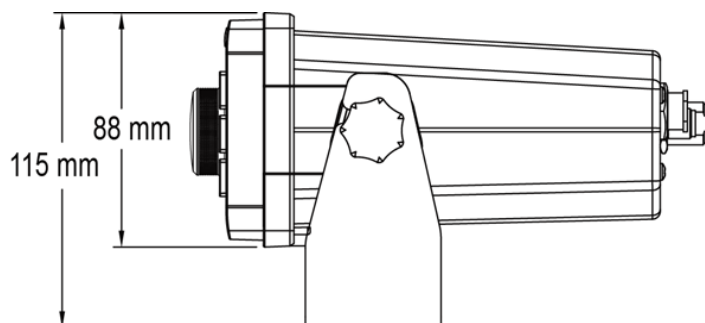

Back (size: mm)

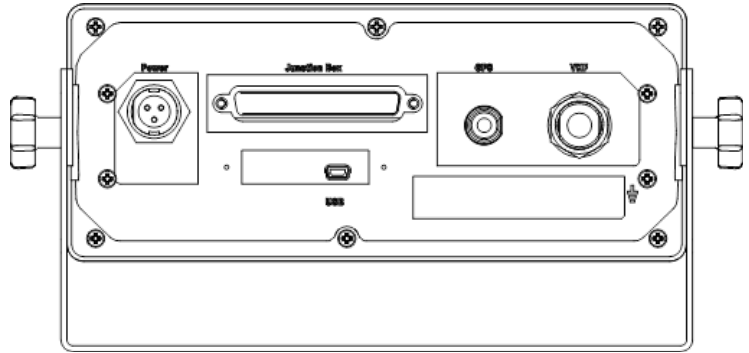

Bottom (size: mm)

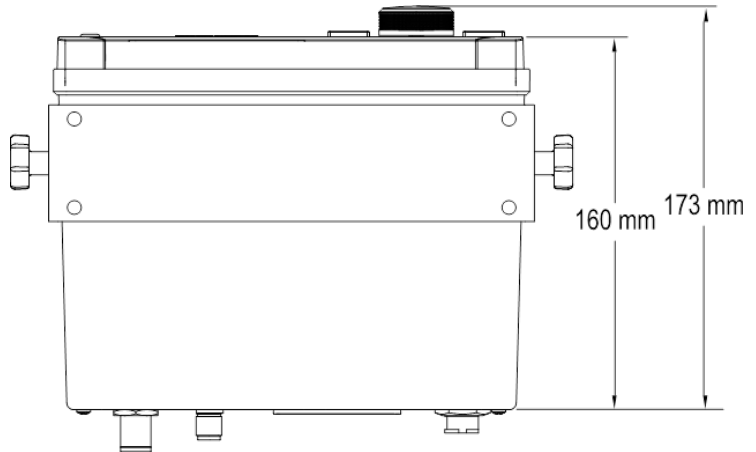

Junction box

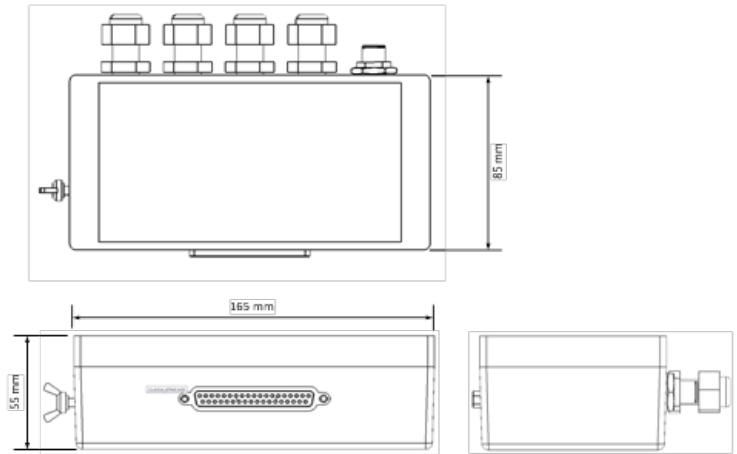

Extension cable

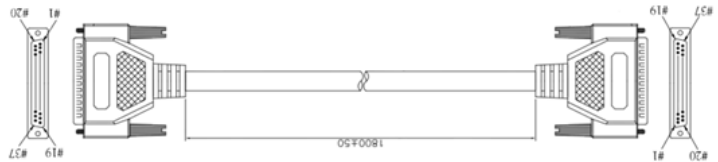

Mounting template (not to scale)

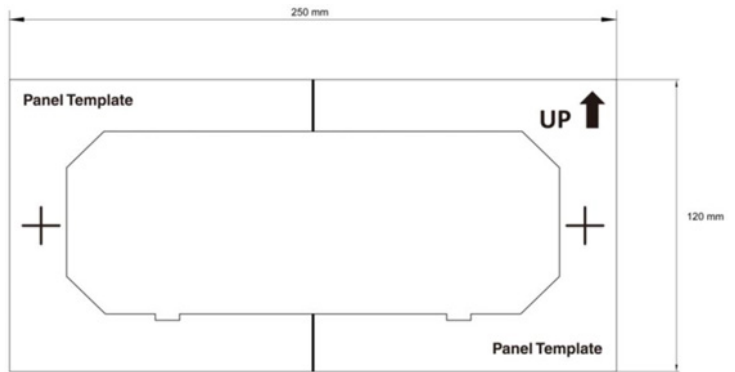

VHF antenna

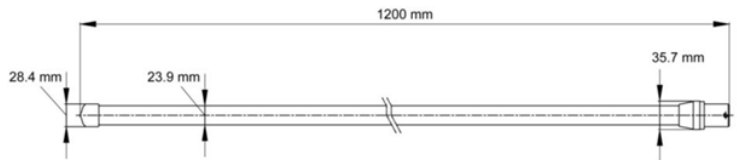

GPS antenna

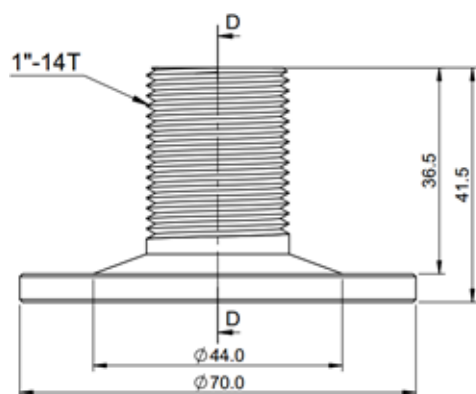
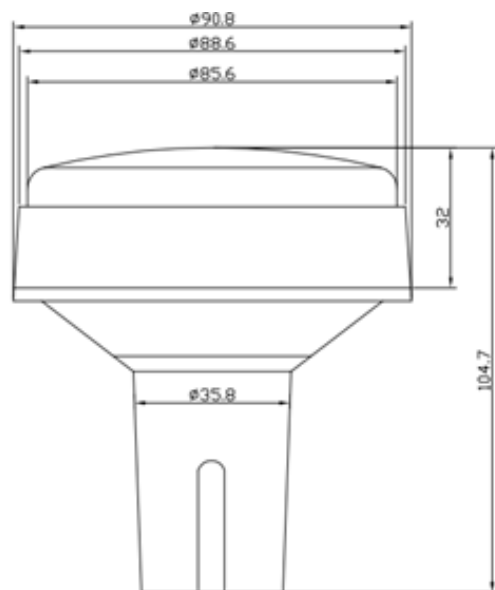

Pilot plug

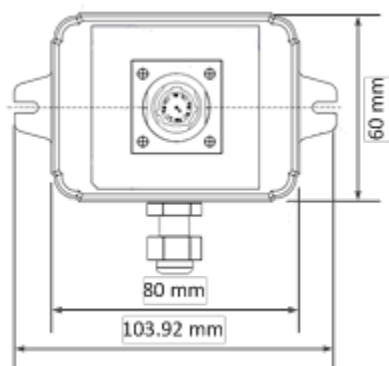
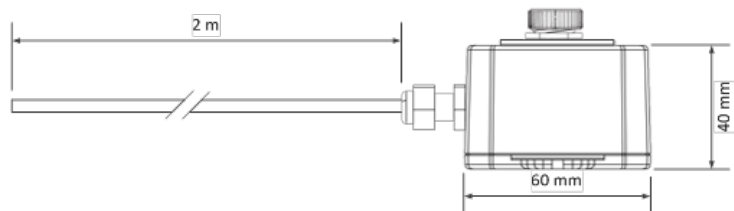

7

Troubleshooting

Use this table to perform simple troubleshooting if the transponder is not functioning as expected.

| Symptom | Possible cause | Solution |
|-----------------------------|------------------------------|--|
| Transponder cannot power on | Faulty connector to power | Check power connection |
| | Polarity reverse | Check power connection |
| | Power supply current too low | Check power supply |
| No picture on display | Unit not powered up | Press power key |
| | Dimmer level set too low | Increase Dimmer level |
| No map detail | Coastline detail not active | Switch to coastline view |
| No GPS position data | Antenna or cabling problem | Check antenna cable and connections |
| No AIS transmission | MMSI not entered | Enter MMSI number |
| | Transmitter disabled | Enable transmitter |
| | Power supply voltage too low | Check power supply |
| No AIS target | VHF cabling problem | Check antenna cable and connections |
| AIS range seems too low | VHF antenna and cabling | Check VHF antenna and cable installation |
| Sensor ports not response | Cable installation | Check related wiring |
| Data port not response | Cable installation | Check related wiring |

8

GN70/MX61X AIS operation

The GN70/MX610/MX612 CDU can display AIS targets provided by the V5035 AIS transponder by pressing the AIS hot key. You can zoom-out by turning the ROTARY KNOB counter-clockwise or zoom-in by turning it in clockwise direction.

AIS targets can be displayed as overlay on the plotter screen. This feature is an important tool for safe travelling and collision avoidance. You need to have your own MMSI (Maritime Mobile Service Identity) number entered in the CDU to be able to receive addressed messages from AIS and DSC vessels. It is also important to have the MMSI number entered to avoid seeing your own vessel as an AIS target on the plotter. You can define alarms to notify you if an AIS target gets too close or if the target is lost.



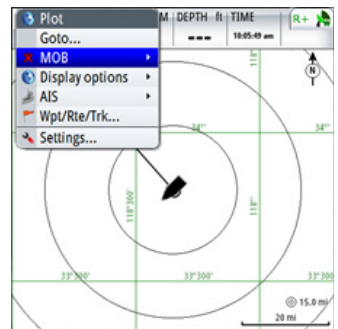

Vessels on AIS/PLOT screen



AIS Plot with Quick Menu

Target symbols

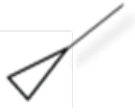
The MX610/MX612 system use the AIS target symbols below:

| Symbol | Description | |
|---|---|--|
|  | Sleeping AIS target (not moving or at anchor) | |
|  | Moving and safe AIS target with course extension line | |
|  | Dangerous AIS target, illustrated with bold line | A target is defined as dangerous based on the CPA and TCPA settings. Refer to Defining dangerous vessels on page 59. |
|  | Lost AIS target | When no signals have been received within a time limit a target will be defined as lost. The target symbol represents the last valid position of the target before the reception of data was lost. |

Viewing information about AIS targets

AIS target list

To display a list of AIS target:

1. Press the AIS hot key.
2. Press the MENU key to bring up the quick menu.
3. The Vessel info menu will be highlighted, press ENT.
4. The list of AIS vessels will show.
5. Scroll to the desired AIS target, press ENT to show the vessel details.
6. Press the ENT key to close.
7. To exit, press the CLR a few times or any hot key.

| AIS | | | |
|--------------|---------------------|-------------|----------------|
| Status - All | | Rx Messages | |
| Name | Distance Bearing | CPA TCPA | Type Status |
| SIM VESSEL A | 5969 mi 154.8 °M | - - | AIS safe |
| SIM VESSEL B | 5969 mi 154.8 °M | - - | AIS safe |
| SIM VESSEL C | 5968 mi 154.8 °M | 0.0 ft - | AIS safe |
| SIM VESSEL D | 5968 mi 154.8 °M | - - | AIS safe |
| SIM VESSEL E | 5970 mi 154.8 °M | - - | AIS safe |

| AIS Vessel Details | |
|--------------------------------|--------------------------|
| SIM VESSEL A (MMSI: 366771124) | |
| Callsign: ABC1234 | Status: Safe |
| IMO: 123 | NavStatus: Under engine |
| AIS Class: A | Draught (ft): 3.3 |
| Type: Unknown | Latitude: N 25°45.0928' |
| Length (ft): 40.0 | Longitude: W 80°07.0921' |
| Beam (ft): 20.0 | Accuracy: High (10m) |
| Bearing (°M): 154.8 | ROT (°/s): 0.0 |
| Distance (mi): 5969 | SOG (mph): 17.3 |
| CPA (mi): | COG (°M): 194.5 |
| TCPA (hrs): | Heading (°M): 194.5 |
| Relative speed (mph): 29.9 | Destination: MIAMI |
| Relative course (°M): 144.5 | ETA: 10/04/2008 12:00 |

Vessel filter

AIS targets displayed can be filtered to hide all targets or safe targets. It can also filter out targets that are further away or traveling at a certain speed:

1. Press the AIS hot key.
2. Press the MENU key to bring up the quick menu.
3. Scroll to Vessels Filter... menu, press ENT.
4. Select desired action by scrolling to it and pressing ENT to leave a check mark.
5. Scroll to SAVE, press ENT.

| Icon Filters | |
|---|---------------------------|
| <input type="checkbox"/> | Hide all |
| <input type="checkbox"/> | Hide safe |
| <input type="checkbox"/> | Hide further than 2 miles |
| <input type="checkbox"/> | Hide slower than 2 mph |
| <input type="button" value="Save"/> <input type="button" value="Cancel"/> | |

Vessel alarms

You can define several alarms to alert you if a target comes within predefined range limits, or if a target is lost.

| Alarm ID | Description |
|------------------|--|
| Dangerous vessel | Controls whether an alarm shall be activated when a vessel comes within the predefined CPA or TCPA. See Defining dangerous vessels on page 59. Note: The check box controls whether the alarm pop-up box is displayed and if the siren will sound. The CPA and TCPA define when a vessel is dangerous regardless of the enabled/disabled state. |
| AIS vessel lost | Sets the range for lost vessels. If a vessel is lost within this range this will trigger an alarm. |
| Vessel message | Controls whether an alarm shall be activated when a message is received from an AIS target. |

→ **Note:** Please refer to the GN70/MX61x User manual for more AIS operation.

9

Abbreviations

| | |
|-------------------|---|
| ACK | Acknowledgement |
| AIS | Automatic Identification System |
| ALR | Alarm |
| ANT | Antenna |
| AtoN | Aid to Navigation |
| AUTO | Automatic |
| AUX | Auxiliary |
| BIIT | Built-In Integrity Test |
| BRG | Bearing |
| CH | Channel |
| COG | Course Over Ground |
| CPA | Closest Point of Approach |
| DEST/DESTN | Destination |
| DISP | Display |
| DGNSS | Differential GNSS |
| DGPS | Differential GPS |
| DISP | Display |
| DIST | Distance |
| DSC | Digital Selective Calling |
| DTE | Data Terminal Equipment |
| ECDIS | Electronic Chart Display and Information System |
| ECS | Electronic Chart System |
| EGNOS | European Geo-stationary Navigational Overlay System |
| ENC | Electronic Navigation Chart |
| EPFS | Electronic Position Fixing System |
| EPIRB | Electronic Position Indicating Radio Beacon |
| ESC | Escape |
| ETA | Estimated Time of Arrival |
| EXT | External |
| FCC | Federal Communications Commission |

| | |
|----------------|---|
| FM | Frequency Modulation |
| FSK | Frequency Shift Keying |
| FUNC | Function |
| GAGAN | GPS-aided geo-augmented navigation |
| GLONASS | Global Orbiting Navigation and Safety System |
| GMDSS | Global Maritime Distress and Safety System |
| GMSK | Gaussian Minimum Shift Keying |
| GND | Ground |
| GNSS | Global Navigation Satellite System |
| GPS | Global Positioning System |
| GYRO | Gyro Compass |
| HDG | Heading |
| IALA | International Association of Lighthouse Authorities |
| I/O | Input/Output |
| ID | Identification |
| IEC | International Electrotechnical Commission |
| IMO | International Maritime Organization |
| IN | Input |
| INFO | Information |
| ITU-R | International Telecommunications Union - Radio |
| KN | Knots |
| LAT | Latitude |
| LCD | Liquid Crystal Display |
| LON | Longitude |
| LR | Long Range |
| MED | Maritime Equipment Directive |
| Min | Minute |
| MKD | Minimum Keyboard and Display |
| MMSI | Maritime Mobile Service Identity |
| MOB | Man Overboard |
| MSAS | Multi-functional Satellite Augmentation System |
| NAV | Navigation |

| | |
|----------------|--|
| NM | Nautical Mile |
| NMEA | National Marine Electronics Association |
| OUT | Output |
| PI | Presentation Interface |
| RAIM | Receiver Autonomous Integrity Monitoring |
| RH | Relative Humidity |
| RNG | Range |
| ROT | Rate of Turn |
| RTCM | Radio Technical Commission for Maritime services |
| Rx | Receive / Receiver |
| S | Second |
| SART | Search and Rescue Transponder |
| SAR | Search and Rescue |
| SBAS | Satellite Based Augmentation System |
| SOG | Speed Over Ground |
| SOLAS | Safety of Life at Sea |
| SRM | Safety Related Message |
| SYS | System |
| TCPA | Time to Closest Point of Approach |
| TDMA | Time Division Multiple Access |
| Tx | Transmit |
| Tx / Rx | Transmit / Receive |
| UHF | Ultra-High Frequency |
| USB | Universal Serial Bus |
| UTC | Universal Time Co-ordinate |
| VDL | VHF Data Link |
| VHF | Very High Frequency |
| VSWR | Voltage Standing Wave Ratio |
| WAAS | Wide Area Augmentation System |

Appendix A

IEC 61162-2 Data Interface

The V5035 Class A AIS Transponder provides 2 types of IEC 61162-2 data interfaces for user applications. The first interface type includes 3 input-only sensor data ports and the second interface type includes 4 bidirectional input/output ports. Data port for each interface type will be described in the following section below.

Sensor data input ports

The schematic of input-only sensor data port is shown in Figure A1. The schematic includes a standard V.11 transceiver IC (Texas Instruments SN65176B) combined with high speed photocoupler which are used as the main components to receive external data. The transceiver IC is isolated from external input. To avoid signal reflection, the transceiver IC has an optional built-in 120Ω loop termination, which is selectable by the dip-switch on the junction box and the switch should be set to on position when connecting external data source with long cable. All sensor data-input ports are isolated from one another and are also isolated from internal power supply. The input impedance on A/B wires is greater than 12 KΩ and the levels on the A/B wires are defined in the following:

- Logic low input: $A-B < -0.2V$
- Logic high input: $A-B > +0.2V$

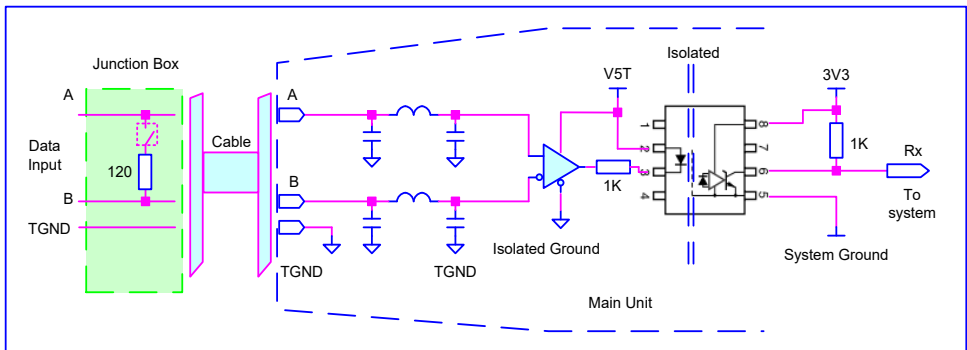

Schematic of sensor data input port

Bidirectional data ports

The schematic of bidirectional data port is shown in Figure A2. The schematics includes an isolated full duplex RS-485 transceiver IC (Texas Instrument ISO3080) which is used as the main component to handle both data input and output from external data source. The transceiver IC is isolated from external input. To avoid signal reflection, the transceiver IC has an optional built-in 120Ω loop termination, which is selectable by the dip-switch on the junction box and the switch should be set to on position when connecting external data source with long cable. All bidirectional data ports are isolated from one another and are also isolated from internal power supply. The transceiver internal power supply is fully isolated from the external power supply.

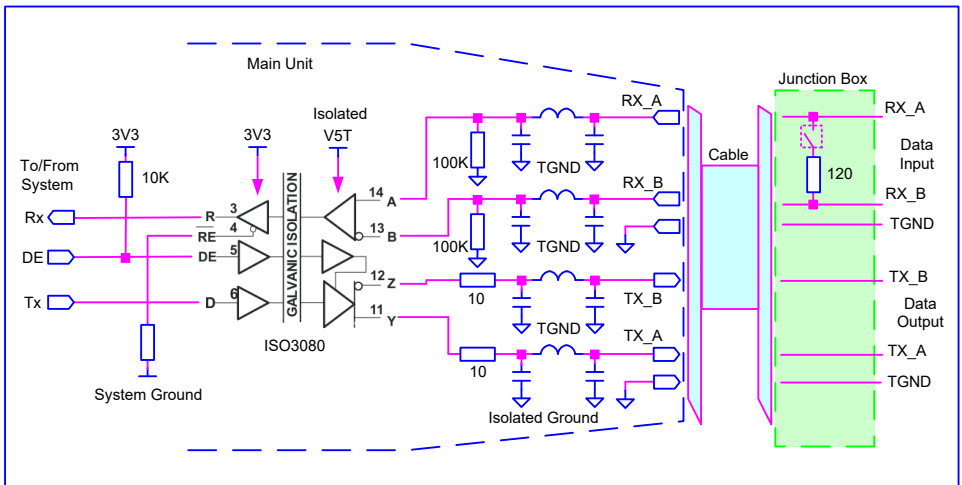

Schematic of bidirectional data port

The output driver capability of bidirectional data port can provide a maximum of 60mA, and the minimum differential output swing under 100 Ω load can be 2.3V.

A and B signal lines

Refer to sections Sensor Data Input Ports (previous page) and Bidirectional Data Ports above.

Output driver

The output driver capability of bi-direction data port can provide maximum 60mA, and the minimum differential output swing under 100 ohm load can be 2.3V.

Input load

Refer to sections Sensor Data Input Ports (previous page) and Bidirectional Data Ports above.

Hardware input/output circuit

Refer to sections Sensor Data Input Ports (previous page) and Bidirectional Data Ports above.

Presentation interface of V5035

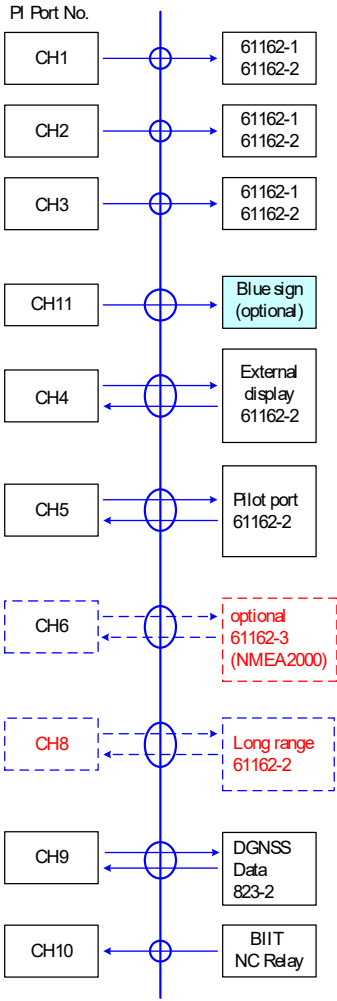

Sensor Inputs

Minimum required input sentences:

| | | |
|---------------|-------------------------|-----------|
| Position | GGA, GLL, GNS, RMC | int/ext * |
| SOG | RMC, VBW, VTG | int/ext * |
| COG | RMC, VBW, VTG | int/ext * |
| Heading | HDT, HDG, OSD, THS, VHW | ext |
| Rotation rate | ROT | ext |
| RAIM | GBS | ext |

* for priority refer to IEC 61993-2

Input / Output of AIS Data

| INPUT | OUTPUT |
|---|---|
| <u>Manual Data Input</u> Voyage VSD Static SSD VDL messages: ABM BBM AIR Interrogation Others: ACA Channel ass. ACK Alarm ack. PAMC Proprietary | <u>VDL messages:</u> VDM (Data block of VDM representing binary Data contents of VDL messages) Others: VDO Own ship data ALR Alarm status ABK VDL ack TXT sensors status ACA channel management information PAMC Proprietary |

Long Range Port (optional)

| | |
|-----------------------|----------------------------|
| <u>Input</u> LRI, LRF | <u>Output</u> LRF, LR1,2,3 |
|-----------------------|----------------------------|

DGNSS Data Port

Correction data information (optional)

BIIT Output Port

Supported IEC 61162 data sentences

| Data Port | Input sentences | Output sentences |
|----------------------------------|---|--|
| Sensor 1 Sensor 2 Sensor 3 | DTM, GBS, GGA, GLL, GNS, GSA, HDG, HDT, OSD, RMC, ROT, THS, VBW, VHW, VTG | N/A |
| DGPS | DTM, GBS, GGA, GLL, GNS, GSA, HDG, HDT, OSD, RMC, ROT, THS, VBW, VHW, VTG | N/A |
| External Display | ABM, ACA, ACK, AIQ, AIR, BBM, EPV, LRF, LRI, SSD, SPW, VSD, ACN | ABK, ACA, ALR, EPV, LR1, LR2, LR3, LRF, TXT, VDM, VDO, ALC, ALF, ARC |
| Pilot | ABM, ACA, ACK, AIQ, AIR, BBM, EPV, LRF, LRI, SSD, SPW, VSD, ACN | ABK, ACA, ALR, EPV, LR1, LR2, LR3, LRF, TXT, VDM, VDO, ALC, ALF, ARC |
| Long Range | LRF, LRI | LR1, LR2, LR3, LRF |

Transmission interval

| Sentence | Interval |
|----------------|---------------------------|
| VDO | Once a second |
| ALR (active) | Once every thirty seconds |
| ALR (inactive) | Once every sixty seconds |

Interpretation of input sentences

ABM – AIS addressed binary and safety related message

This sentence supports ITU-R M.1371 Messages 6, 12, 25, 26 and provides an external application with a means to exchange data via an AIS transponder.

| !-ABM,x,x,x,xxxxxxxxx,x,xx,s—s,x*hh<CR><LF> | | | |
|---|----------|---|--------|
| Field no. | Format | Description | Remark |
| 1 | x | Total number of sentences needed to transfer the message | |
| 2 | x | Sentence number | |
| 3 | x | Sequential message identifier | |
| 4 | xxxxxxxx | The MMSI of the destination AIS unit for the ITU-R M.1371 message | |

| | | | |
|---|-----|--|--|
| 5 | x | AIS channel for broadcast of the radio message | |
| 6 | xx | ITU-R M.1371 message ID | |
| 7 | s—s | Encapsulated data | |
| 8 | x | Number of fill-bits | |

ACA – AIS channel assignment message

An AIS device can receive regional channel management information.

`$--ACA,x,IIII.II,a,yyyyy.yy,a,IIII.II,a,yyyyy.yy,a,x,xxxx,x,xxxx,x,x,x,a,x,hhmmss.ss*hh<CR><LF>`

| Field no. | Format | Description | Remark |
|-----------|------------|---|--------|
| 1 | x | Sequence Number | |
| 2 | IIII.II,a | Region northeast corner latitude – N/S | |
| 3 | yyyyy.yy,a | Region northeast corner longitude – E/W | |
| 4 | IIII.II,a | Region southwest corner latitude – N/S | |
| 5 | yyyyy.yy,a | Region southwest corner longitude – E/W | |
| 6 | x | Transition zone size | |
| 7 | xxxx | Channel A | |
| 8 | x | Channel A bandwidth | |
| 9 | xxxx | Channel B | |
| 10 | x | Channel B bandwidth | |
| 11 | x | Tx/Rx mode control | |
| 12 | x | Power level control | |
| 13 | a | Information source | |
| 14 | x | In-use flag | |
| 15 | hhmmss.ss | Time of “in use” change | |

ACK – Acknowledge alarm

This sentence is used to acknowledge an alarm condition reported by a device.

`$--ACK,xxx*hh<CR><LF>`

| Field no. | Format | Description | Remark |
|-----------|--------|--|--------|
| 1 | xxx | Unique alarm number (identifier) at alarm source | |

ACN – Alert command

This sentence is used for acknowledge, silence, responsibility transfer and to request repeat of alert details in case the reception process has detected, based on ALC, that ALF has been missed.

| \$--ACN,hhmmss.ss,aaa,x.x,x.x,c,a*hh <CR><LF> | | | |
|---|-----------|-----------------------------|--------|
| Field no. | Format | Description | Remark |
| 1 | hhmmss.ss | Time | |
| 2 | aaa | Manufacturer mnemonic code | |
| 3 | x.x | Alert Identifier | |
| 4 | x.x | Alert Instance, 1 to 999999 | |
| 5 | c | Alert command, A, Q, O or S | |
| 6 | a | Sentence status flag | |

AIQ - Query sentence

This sentence is used to inquire AIS sentence information.

| \$--AIQ,c—c*hh<CR><LF> | | | |
|------------------------|--------|---|--------|
| Field no. | Format | Description | Remark |
| 1 | c—c | Support query sentence of ACA, EPV, SSD, VSD, TXT | |

AIR – AIS interrogation request

This sentence supports ITU-R M.1371 messages 15 and 10. It provides an external application with the means to initiate requests for specific ITU-R M.1371 messages from AIS unit.

| \$--AIR,xxxxxxxx,x.x,x.x,x.x,xxxxxxxx,x.x,x*hh<CR><LF> | | | |
|--|----------|---|---------|
| Field no. | Format | Description | Remark |
| 1 | xxxxxxxx | MMSI of interrogated station 1 | |
| 2 | x.x | ITU-R M.1371 message requested from station-1 | |
| 3 | x | Message sub-section | ignored |
| 4 | x.x | Number of second message requested from station-1 | |
| 5 | x | Message sub-section | ignored |
| 6 | xxxxxxxx | MMSI of interrogated station-2 | |
| 7 | x.x | Number of messages requested from station-2 | |
| 8 | x | Message sub-section | ignored |

BBM – AIS broadcast binary message

This sentence supports generation of ITU-R M.1371 binary messages 8, 14, 25, and 26. This provides the application with a means to broadcast data, as defined by the application only.

| !-BBM,x,x,x,x,x,x,s—s,x*hh<CR><LF> | | | |
|------------------------------------|--------|--|--------|
| Field no. | Format | Description | Remark |
| 1 | x | Total number of sentences needed to transfer the message | |
| 2 | x | Sentence number | |
| 3 | x | Sequential message identifier | |
| 4 | x | AIS channel for broadcast of the radio message | |
| 5 | x.x | ITU-R M.1371 Message ID | |
| 6 | s—s | Encapsulated data | |
| 7 | x | Number of fill-bits | |

DTM – Datum reference

Local geodetic datum and datum offsets from a reference datum.

| \$--DTM,ccc,a,x.x,a,x.x,a, x.x,ccc*hh<CR><LF> | | | |
|---|--------|------------------------------|---------|
| Field no. | Format | Description | Remark |
| 1 | ccc | Local datum | |
| 2 | a | Local datum subdivision code | ignored |
| 3 | x.x, a | Lat offset, min, N/S | ignored |
| 4 | x.x, a | Lon offset, min, E/W | ignored |
| 5 | x.x | Altitude offset, m | ignored |
| 6 | ccc | Reference datum | |

EPV – Command or report equipment property value

| \$--DTM,ccc,a,x.x,a,x.x,a, x.x,ccc*hh<CR><LF> | | | |
|---|--------|-----------------------------|--------|
| Field no. | Format | Description | Remark |
| 1 | a | Sentence status flag | |
| 2 | cc | Destination equipment type | |
| 3 | c--c | Unique identifier | |
| 4 | x.x | Property identifier | |
| 5 | c--c | Value of property to be set | |

GBS – GNSS satellite fault detection

This sentence is used to support receiver autonomous integrity monitoring (RAIM).

| \$--GBS, hhmss.ss, x.x, x.x, x.x, xx, x.x, x.x, x.x *hh <CR><LF> | | | |
|--|----------|--|---------|
| Field no. | Format | Description | Remark |
| 1 | hhmss.ss | UTC time of the GGA or GNS fix associated with this sentence | |
| 2 | x.x | Expected error in latitude | |
| 3 | x.x | Expected error in longitude | |
| 4 | x.x | Expected error in altitude | ignored |
| 5 | xx | ID number of most likely failed satellite | ignored |
| 6 | x.x | Probability of missed detection for most likely failed satellite | ignored |
| 7 | x.x | Estimate of bias on most likely failed satellite | ignored |
| 8 | x.x | Standard deviation of bias estimate | ignored |

GGA – Global positioning system (GPS) fix data

Time, position and fix-related data for a GPS receiver.

| \$--GGA, hhmss.ss, llll.ll, a, yyyy.yy, a, x, xx, x.x, x.x, M, x.x, M, x.x, xxxx*hh<CR><LF> | | | |
|---|-----------|--|---------|
| Field no. | Format | Description | Remark |
| 1 | hhmss.ss | UTC of position | |
| 2 | llll.ll,a | Latitude N/S | |
| 3 | yyyy.yy,a | Longitude E/W | |
| 4 | x | GPS quality indicator | ignored |
| 5 | xx | Number of satellites in use, 00-12, may be different from the number in view | ignored |
| 6 | x.x | Horizontal dilution of precision | ignored |
| 7 | x.x | Antenna altitude above/below mean sea level (geoid) | ignored |
| 8 | M | Units of antenna altitude, m | ignored |
| 9 | x.x | Geoidal separation | ignored |
| 10 | M | Units of geoidal separation, m | ignored |
| 11 | x.x | Age of differential GPS data | ignored |
| 12 | xxxx | Differential reference station ID, 0000-1023 | ignored |

GLL – Geographic position – latitude/longitude

Latitude and longitude of vessel position, time of position fix and status.

| \$--GLL, llll.ll, a, yyyyy.yy, a, hhhmss.ss, A, a *hh<CR><LF> | | | |
|---|-------------|-------------------------------------|--------|
| Field no. | Format | Description | Remark |
| 1 | llll.ll, a | Latitude, N/S | |
| 2 | yyyyy.yy, a | Longitude, E/W | |
| 3 | hhmss.ss | UTC of position | |
| 4 | A | Status, A=data valid V=data invalid | |
| 5 | a | Mode indicator | |

GNS – GNSS fix data

Fix data for single or combined satellite navigation systems (GNSS). This sentence provides fix data for GPS, GLONASS, possible future satellite systems and systems combining these.

| \$-- GNS, hhhmss.ss, llll.ll, a, yyyyy.yy, a, c--c,x,x,x,x,x,x,x,x,x,x,a *hh<CR><LF> | | | |
|--|-------------|--|---------|
| Field no. | Format | Description | Remark |
| 1 | hhmss.ss | UTC of position | |
| 2 | llll.ll, a | Latitude, N/S | |
| 3 | yyyyy.yy, a | Longitude, E/W | |
| 4 | c--c | Mode indicator | |
| 5 | xx | Total number of satellites in use | ignored |
| 6 | x.x | HDOP | ignored |
| 7 | x.x | Antenna altitude, m, re:mean-sea-level (geoid) | ignored |
| 8 | x.x | Geoidal separation, m | ignored |
| 9 | x.x | Age of differential data | ignored |
| 10 | x.x | Differential reference station ID | ignored |
| 11 | a | Nacigational status indicator | |

GSA – GNSS DOP and active satellites

GNSS receiver operating mode, satellites used in the navigation solution reported by the GGA or GNS sentences and DOP values. If only GPS, GLONASS, etc. are used for the reported position solution, the talker ID is GP, GL, etc. and the DOP values pertain to the individual system.

| \$--GSA, a, x, xx,xx,xx,xx,xx,xx,xx,xx,xx,xx,xx,x.x,x.x,x.x*hh<CR><LF> | | | |
|--|-------------------------------------|---|--------|
| Field no. | Format | Description | Remark |
| 1 | a | Mode: M = manual, forced to operate in 2D or 3D mode A = automatic, allowed to automatically switch 2D/3D | |
| 2 | x | Mode: 1 = fix not available, 2 = 2D, 3 = 3D | |
| 3 | xx,xx,xx,xx,xx,xx,xx,xx,xx,xx,xx,xx | ID numbers of satellites used in solution | |
| 4 | x.x | PDOP | |
| 5 | x.x | HDOP | |
| 6 | x.x | VDOP | |

HDG – Heading, deviation and variation

Heading (magnetic sensor reading), which if corrected for deviation will produce magnetic heading, which if offset by variation will provide true heading.

| \$--HDG, x.x, x.x, a, x.x, a*hh<CR><LF> | | | |
|---|--------|----------------------------------|--------|
| Field no. | Format | Description | Remark |
| 1 | x.x | Magnetic sensor heading, degrees | |
| 2 | x.x,a | Magnetic deviation, degrees E/W | |
| 3 | x.x,a | Magnetic variation,degrees E/W | |

HDT – Heading true

Actual vessel heading in degrees true produced by any device or system producing true heading.

| \$--HDT, x.x, T*hh<CR><LF> | | | |
|----------------------------|--------|-----------------------|--------|
| Field no. | Format | Description | Remark |
| 1 | x.x, T | Heading, degrees true | |

LRF – AIS long-range function

This sentence is used in both long-range interrogation requests and long-range interrogation replies. The LRF-sentence is the second sentence of the long-range interrogation request pair, LRI and LRF (see the LRI-sentence).

| \$--LRF,x,xxxxxxxx,c—c,c—c,c—c*hh<CR><LF> | | | |
|---|----------|-----------------------|--------|
| Field no. | Format | Description | Remark |
| 1 | x | Sequence number | |
| 2 | xxxxxxxx | MMSI of requestor | |
| 3 | c—c | Name of requestor | |
| 4 | c—c | Function request | |
| 5 | c—c | Function reply status | |

LRI – AIS long-range interrogation

The long-range interrogation of the AIS unit is accomplished through the use of two sentences. The pair of interrogation sentence formatters, a LRI sentence followed by a LRF sentence, provides the information needed by a universal AIS unit to determine if it should construct and provide the reply sentences (LRF, LR1, LR2, and LR3).

| \$--LRI,x,a,xxxxxxxx,xxxxxxxx,IIII.II,a,yyyyy.yy,a,IIII.II,a,yyyyy.yy,a*hh<CR><LF> | | | |
|--|------------|---------------------|--------|
| Field no. | Format | Description | Remark |
| 1 | x | Sequence number | |
| 2 | a | Control flag | |
| 3 | xxxxxxxx | MMSI of requestor | |
| 4 | xxxxxxxx | MMSI of destination | |
| 5 | IIII.II,a | Latitude – N/S | |
| 6 | yyyyy.yy,a | Longitude – E/W | |
| 7 | IIII.II,a | Latitude – N/S | |
| 8 | yyyyy.yy,a | Longitude – E/W | |

OSD – Own ship data

Heading, course, speed, set and drift summary. Useful for, but not limited to radar/ARPA applications. OSD gives the movement vector of the ship based on the sensors and parameters in use.

| \$--OSD, x.x,A,x.x, a,x.x,a,x.x,x.x,a*hh<CR><LF> | | | |
|--|--------|--|---------|
| Field no. | Format | Description | Remark |
| 1 | x.x | Heading, degrees true | |
| 2 | A | Heading status: A = data valid, V = data invalid | |
| 3 | x.x | Vessel course, degrees true | Ignored |
| 4 | a | Course reference, B/M/W/R/P (see Note) | Ignored |
| 5 | x.x | Vessel speed | Ignored |
| 6 | a | Speed reference,B/M/W/R/P (see Note) | Ignored |
| 7 | x.x | Vessel set, degrees true | Ignored |
| 8 | x.x | Vessel drift (speed) | Ignored |
| 9 | a | Speed units, K = km/h; N = knots; S = statute miles/h | ignored |

RMC – Recommended minimum specific GNSS data

Time, date, position, course and speed data provided by a GNSS navigation receiver.

| \$-- GNS, hhmss.ss, llll.ll, a, yyyy.yy, a, c--c,xx,x.x,x.x,x.x,x.x,x.x,a*hh<CR><LF> | | | |
|--|------------|----------------------------------|--------|
| Field no. | Format | Description | Remark |
| 1 | hhmss.ss | UTC of position fix | |
| 2 | A | Status | |
| 3 | llll.ll,a | Latitude, N/S | |
| 4 | yyyy.yy, a | Longitude, E/W | |
| 5 | x.x | Speed over ground, knots | |
| 6 | x.x | Course over ground, degrees true | |
| 7 | xxxxxx | Date: dd/mm/yy | |
| 8 | x.x,a | Magnetic variation, degrees, E/W | |
| 9 | a | Mode indicator | |
| 10 | a | Navigational status | |

ROT – Rate of turn

Rate of turn and direction of turn.

| \$--ROT, x.x, A*hh<CR><LF> | | | |
|----------------------------|--------|--|--------|
| Field no. | Format | Description | Remark |
| 1 | x.x | Rate of turn, °/min | |
| 2 | A | Status: A = data valid, V = data invalid | |

SPW - Security password sentence

This sentence can be used for authentication. For this purpose the sentence has to be applied before the protected sentence (for example EPV, SSD).

| \$--SPW,ccc,c--c,x,c--c*hh<CR><LF> | | | |
|------------------------------------|--------|-----------------------------|--------|
| Field no. | Format | Description | Remark |
| 1 | ccc | Password protected sentence | |
| 2 | c--c | Unique Identifier | |
| 3 | x | Password level | |
| 4 | c--c | Password | |

SSD – AIS ship static data

This sentence is used to enter static parameters into a shipboard AIS unit. The parameters in this sentence support a number of the ITU-R M.1371 Messages.

| \$--SSD,c—c,c—c,xxx,xxx,xx,xx,c,aa*hh<CR><LF> | | | |
|---|--------|----------------------------|--------|
| Field no. | Format | Description | Remark |
| 1 | c—c | Ship's call sign | |
| 2 | c—c | Ship's name | |
| 3 | xxx | Pos. ref., point dist."A," | |
| 4 | xxx | Pos. ref.,point dist. "B," | |
| 5 | xx | Pos. ref., point dist."C," | |
| 6 | xx | Pos. ref.,point dist. "D," | |
| 7 | c | DTE indicator flag | |
| 8 | aa | Source identifier | |

THS – True heading and status

Actual vessel heading in degrees true produced by any device or system producing true heading. This sentence includes a "mode indicator" field providing critical safety related information about the heading data, and replaces the deprecated HDT sentence.

| \$--THS,x.x,a*hh<CR><LF> | | | |
|--------------------------|--------|-----------------------|--------|
| Field no. | Format | Description | Remark |
| 1 | x.x | Heading, degrees true | |
| 2 | a | Mode indicator | |

VBW – Dual ground/water speed

Water-referenced and ground-referenced speed data

| \$--VBW, x.x, x.x, A, x.x, x.x, A, x.x, A, x.x, A*hh<CR><LF> | | | |
|--|--------|--|---------|
| Field no. | Format | Description | Remark |
| 1 | x.x | Longitudinal water speed, knots | ignored |
| 2 | x.x | Transverse water speed , knots | ignored |
| 3 | A | Status : water speed, A = data valid, V = data invalid | ignored |
| 4 | x.x | Longitudinal ground speed , knots | |
| 5 | x.x | Transverse ground speed , knots | |
| 6 | A | Status , ground speed, A = data valid, V = data invalid | |
| 7 | x.x | Stern transverse water speed , knots | ignored |
| 8 | A | Status : stern water speed,A = data valid, V = data invalid | ignored |
| 9 | x.x | Stern transverse ground speed ,knots | ignored |
| 10 | A | Status : stern ground speed,A = data valid, V = data invalid | ignored |

VHW – Water speed and heading

The compass heading to which the vessel points and the speed of the vessel relative to the water

| \$--VHW, x.x, T, x.x, M, x.x, N, x.x, K*hh<CR><LF> | | | |
|--|--------|---------------------------|---------|
| Field no. | Format | Description | Remark |
| 1 | x.x, T | Heading, degrees true | |
| 2 | x.x, M | Heading, degrees magnetic | Ignored |
| 3 | x.x, N | Speed, knots | Ignored |
| 4 | x.x, K | Speed, km/h | Ignored |

VSD – AIS voyage static data

This sentence is used to enter information about a ship's transit that remains relatively static during the voyage

| \$--VSD,x.x,x.x,x.x,c—c,hhmmss.ss,xx,xx,x.x,x.x*hh<CR><LF> | | | |
|--|-----------|---|--------|
| Field no. | Format | Description | Remark |
| 1 | x.x | Type of ship and cargo category | |
| 2 | x.x | Maximum present static draught | |
| 3 | x.x | Persons on-board | |
| 4 | c—c | Destination | |
| 5 | hhmmss.ss | Estimated UTC of arrival at destination | |
| 6 | xx | Estimated day of arrival at destination | |
| 7 | xx | Estimated month of arrival at destination | |
| 8 | x.x | Navigational status | |
| 9 | x.x | Regional application flags | |

VTG – Course over ground and ground speed

The actual course and speed relative to the ground

| \$--VTG, x.x, T, x.x, M, x.x, N, x.x, K,a*hh<CR><LF> | | | |
|--|--------|--------------------------------------|---------|
| Field no. | Format | Description | Remark |
| 1 | x.x, T | Course over ground, degrees true | |
| 2 | x.x, M | Course over ground, degrees magnetic | ignored |
| 3 | x.x, N | Speed over ground, knots | |
| 4 | x.x, K | Speed over ground, km/h | ignored |
| 5 | a | Mode indicator | |

PAMC, DBG – Proprietary sentences, debug

The proprietary sentences are additional sentences only applicable to this product. Its main usage is for enabling testing mode and parameter settings.

This sentence is used for configuration. It commands unit with given parameters.

| \$PAMC,C,c-c,x,x,x,x,x,x,x,x*hh<CR><LF> | | | |
|---|--------|-----------------------------------|--------|
| Field no. | Format | Description | Remark |
| 1 | C | Command : "C" | |
| 2 | c-c | Function type. For example, DBG. | |
| 3 | x | Parameter Id 1 , 0-998 | |
| 4 | x | Parameter value 1 , 0- 1000000000 | |
| 5 | x | Parameter Id 2 , 0-998 | |
| 6 | x | Parameter value 2, 0- 1000000000 | |
| 7 | x | Parameter Id 3 , 0-998 | |
| 8 | x | Parameter value 3, 0- 1000000000 | |
| 9 | x | Parameter Id 4 , 0-998 | |
| 10 | x | Parameter value 4, 0- 1000000000 | |

This sentence is used for retrieving responses:

| \$PAMC,R,c-c,x,x,x,x,x,x,x,x*hh<CR><LF> | | | |
|---|--------|-----------------------------------|--------|
| Field no. | Format | Description | Remark |
| 1 | R | Response : "R" | |
| 2 | c-c | Function type. For example, DBG. | |
| 3 | x | Parameter Id 1 , 0-998 | |
| 4 | x | Parameter value 1 , 0- 1000000000 | |
| 5 | x | Parameter Id 2 , 0-998 | |
| 6 | x | Parameter value 2, 0- 1000000000 | |
| 7 | x | Parameter Id 3 , 0-998 | |
| 8 | x | Parameter value 3, 0- 1000000000 | |
| 9 | x | Parameter Id 4 , 0-998 | |
| 10 | x | Parameter value 4, 0- 1000000000 | |

PAMC, DSC – Proprietary sentences, digital selective calling

When AIS transponder receives DCS messages, this sentence is used to output DSC pattern.

| \$PAMC,R,DSC,c-c*hh<CR><LF> | | | |
|-----------------------------|--------|-------------|--------|
| Field no. | Format | Description | Remark |
| 1 | c-c | DSC pattern | |

Interpretation of output sentences

ABK – AIS Addressed and binary broadcast acknowledgement

The ABK-sentence is generated when a transaction, initiated by reception of an ABM, AIR, or BBM sentence, is completed or terminated.

| \$--ABK,xxxxxxxx,x,x.x,x,x*hh<CR><LF> | | | |
|---------------------------------------|----------|--------------------------------|--------|
| Field no. | Format | Description | Remark |
| 1 | xxxxxxxx | MMSI of the addressed AIS unit | |
| 2 | x | AIS channel of reception | |
| 3 | x.x | ITU-R M.1371 Message ID | |
| 4 | x | Message sequence number | |
| 5 | x | Type of acknowledgement | |

ACA – AIS channel assignment message

An AIS device can receive regional channel management information.

| \$-ACA,x,IIII.II,a,yyyyy.yy,a,IIII.II,a,yyyyy.yy,a,x,xxxx,x,xxxx,x,x,x,a,x,hhmss.ss*hh<CR><LF> | | | |
|--|------------|---|--------|
| Field no. | Format | Description | Remark |
| 1 | x | Sequence Number | |
| 2 | IIII.II,a | Region northeast corner latitude – N/S | |
| 3 | yyyyy.yy,a | Region northeast corner longitude – E/W | |
| 4 | IIII.II,a | Region southwest corner latitude – N/S | |
| 5 | yyyyy.yy,a | Region southwest corner longitude – E/W | |
| 6 | x | Transition zone size | |
| 7 | xxxx | Channel A | |

| | | | |
|----|-----------|-------------------------|--|
| 8 | x | Channel A bandwidth | |
| 9 | xxxx | Channel B | |
| 10 | x | Channel B bandwidth | |
| 11 | x | Tx/Rx mode control | |
| 12 | x | Power level control | |
| 13 | a | Information source | |
| 14 | x | In-use flag | |
| 15 | hhmmss.ss | Time of "in use" change | |

ALC – Cyclic alert list

The purpose of this sentence is to satisfy the needs for a safe and consistent data distribution with a minimum of data traffic. Each change on an alert's data leads to an incremented Revision counter. So an alert processing device only needs to check the alert entries in the ALC messages to ensure that no ALF message has been lost.

| §--ALC,xx,xx,xx,x,x,aaa,x,x,x,x,x,.....,aaa,x,x,x,x,x*hh <CR><LF> | | | |
|---|---------------|--|--------|
| Field no. | Format | Description | Remark |
| 1 | xx | Total number of sentences for this message, 01 to 99 | |
| 2 | xx | Sentence number, 01 to 99 1 | |
| 3 | xx | Sequential message identifier, 00 to 99 | |
| 4 | x.x | Number of alert entries | |
| 5 | aaa | Manufacturer mnemonic code | |
| 6 | x.x | Alert identifier | |
| 7 | x.x | Alert instance | |
| 8 | x.x | Revision counter | |
| 9 | | Additional Alert entries | |
| 10 | aaa,x,x,x,x,x | Alert entry n | |

ALF – Alert sentence

This sentence is used to report an alert condition and the alert state of a device. An ALF message shall be published for an alert each time the alert information in this sentence changes and on alert request.

| \$--ALF,x,x,x,hhmmss.ss,a,a,aaa,x,x,x,x,x,x,c---c*hh <CR><LF> | | | |
|---|-----------|--|--------|
| Field no. | Format | Description | Remark |
| 1 | x | Total number of ALF sentences for this message, 1 to 2 | |
| 2 | x | Sentence number, 1 to 2 | |
| 3 | x | Sequential message identifier, 0 to 9 | |
| 4 | hhmmss.ss | Time of last change | |
| 5 | a | Alert category, A, B or C | |
| 6 | a | Alert priority, E, A, W or C | |
| 7 | a | Alert state, A, S, N, O, U or V | |
| 8 | aaa | Manufacturer mnemonic code | |
| 9 | x.x | Alert identifier | |
| 10 | x.x | Alert instance, 1 to 999999 | |
| 11 | x.x | Revision counter, 1 to 99 | |
| 12 | x | Escalation counter, 0 to 9 | |
| 13 | c---c | Alert text | |

ALR – Set alarm state

Local alarm condition and status. This sentence is used to report an alarm condition on a device and its current state of acknowledgement.

| \$--ALR,hhmmss.ss,xxx,A,A,c--c*hh<CR><LF> | | | |
|---|-----------|--|--------|
| Field no. | Format | Description | Remark |
| 1 | hhmmss.ss | Time of alarm condition change, UTC | |
| 2 | xxx | Unique alarm number (identifier) at alarm source | |
| 3 | A | Alarm condition, A = threshold exceeded, V = not exceeded | |
| 4 | A | Alarm's acknowledge state, A = acknowledged, V = unacknowledged | |
| 5 | c--c | Alarm's description text | |

ARC – Alert command refused

This sentence is used for which it is illegal to accept acknowledge or responsibility transfer, e.g. not enough information for decision support available or the source of acknowledgement is not acceptable.

| \$--ARC,hhmmss.ss,aaa,x.x,x.x,c*hh <CR><LF> | | | |
|---|-----------|-------------------------------------|--------|
| Field no. | Format | Description | Remark |
| 1 | hhmmss.ss | Time | |
| 2 | aaa | Manufacturer mnemonic code | |
| 3 | x.x, | Alert identifier | |
| 4 | x.x, | Alert instance, 1 to 999999 | |
| 5 | c | Refused alert command, A, Q, O or S | |

EPV – Command or report equipment property value

| \$--EPV,a,cc,c--c,x.x,c--c*hh<CR><LF> | | | |
|---------------------------------------|--------|-----------------------------|--------|
| Field no. | Format | Description | Remark |
| 1 | a | Sentence status flag | |
| 2 | cc | Destination equipment type | |
| 3 | c--c | Unique identifier | |
| 4 | x.x | Property identifier | |
| 5 | c--c | Value of property to be set | |

LR1 – AIS long-range reply sentence 1

The LR1 sentence identifies the destination for the reply and contains the information items requested by the "A" function identification character (see the LRF sentence).

| \$--LR1,x,xxxxxxxx,xxxxxxxx,c—c,c—c,xxxxxxxx*hh<CR><LF> | | | |
|---|----------|---------------------------------|--------|
| Field no. | Format | Description | Remark |
| 1 | x | Sequence number | |
| 2 | xxxxxxxx | MMSI of responder | |
| 3 | xxxxxxxx | MMSI of requestor | |
| 4 | c—c | Ship's name, 1 to 20 characters | |
| 5 | c—c | Call sign, 1 to 7 characters | |
| 6 | xxxxxxxx | IMO number, 9-digit number | |

LR2 – AIS long-range reply sentence 2

The LR2-sentence contains the information items requested by the “B, C, E and F” function identification characters,(see the LRF sentence)

| \$--LR2,x,xxxxxxxx,xxxxxxxx,hhmmss.ss,lll.l,a,yyyy.yy,a,x.x,T,x.x,N*hh<CR><LF> | | | |
|--|-----------|-----------------------------------|--------|
| Field no. | Format | Description | Remark |
| 1 | x | Sequence number | |
| 2 | xxxxxxxx | MMSI of responder | |
| 3 | xxxxxxxx | Date: ddmmyyy, 8 digits | |
| 4 | hhmmss.ss | UTC time of position | |
| 5 | lll.l,a | Latitude – N/S | |
| 6 | yyyy.yy,a | Longitude, E/W | |
| 7 | x.x,T | Course over ground, degrees, true | |
| 8 | x.x,N | Speed over ground, knots | |

LR3 – AIS long-range reply sentence 3

The LR3 sentence contains the information items requested by the “I, O, P, U and W” function identification character (see the LRF sentence).

| \$--LR3,x,xxxxxxxx,c—c,xxxxx,hhmmss.ss,x.x,x.x,x.x,x.x,x.x,x.x*hh<CR><LF> | | | |
|---|-----------|-----------------------------------|--------|
| Field no. | Format | Description | Remark |
| 1 | x | Sequence number | |
| 2 | xxxxxxxx | MMSI of responder | |
| 3 | c—c | Voyage destination, 1 to 20 chars | |
| 4 | xxxxx | ETA date: ddmmyy | |
| 5 | hhmmss.ss | ETA time | |
| 6 | x.x | Draught | |
| 7 | x.x | Ship/cargo | |
| 8 | x.x | Ship length | |
| 9 | x.x | Ship breadth | |
| 10 | x.x | Ship type | |
| 11 | x.x | Persons, 0 to 8191 | |

LRF – AIS long-range function

This sentence is used in both long-range interrogation requests and long-range interrogation replies. The LRF-sentence is the second sentence of the long-range interrogation request pair, LRI and LRF (see the LRI-sentence).

| \$--LRF,x,xxxxxxxx,c--c,c--c*c*hh<CR><LF> | | | |
|---|----------|-----------------------|--------|
| Field no. | Format | Description | Remark |
| 1 | x | Sequence number | |
| 2 | xxxxxxxx | MMSI of requestor | |
| 3 | c--c | Name of requestor | |
| 4 | c--c | Function request | |
| 5 | c--c | Function reply status | |

TXT – Text transmission

For the transmission of short text messages. Longer text messages may be transmitted by using multiple sentences.

| \$--TXT,xx,xx,xx,c--c*c*hh<CR><LF> | | | |
|------------------------------------|--------|---------------------------|--------|
| Field no. | Format | Description | Remark |
| 1 | xx | Total number of sentences | |
| 2 | xx | Sentence number | |
| 3 | xx | Text identifier | |
| 4 | c--c | Text message | |

VDM – AIS VHF data-link message

This sentence is used to transfer the entire contents of a received AIS message packet, as defined in ITU-R M.1371 and as received on the VHF Data Link (VDL), using the “six-bit” field type.

| !--VDM,x,x,x,a,s--s,x*hh<CR><LF> | | | |
|----------------------------------|--------|--|--------|
| Field no. | Format | Description | Remark |
| 1 | x | Total number of sentences needed to transfer the message | |
| 2 | x | Sentence number | |
| 3 | x | Sequential message identifier | |
| 4 | a | AIS channel | |
| 5 | s--s | Encapsulated ITU-R M.1371 radio message | |
| 6 | x | Number of fill-bits | |

VDO – AIS VHF data-link own-vessel report

This sentence is used to transfer the entire contents of an AIS unit's broadcast message packet, as defined in ITU-R M.1371 and as sent out by the AIS unit over the VHF data link (VDL) using the "six-bit" field type.

| !-VDO,x,x,x,a,s—s,x*hh<CR><LF> | | | |
|--------------------------------|--------|--|--------|
| Field no. | Format | Description | Remark |
| 1 | x | Total number of sentences needed to transfer the message | |
| 2 | x | Sentence number | |
| 3 | x | Sequential message identifier | |
| 4 | a | AIS channel | |
| 5 | s—s | Encapsulated ITU-R M.1371 radio message | |
| 6 | x | Number of fill-bits | |

Appendix B

Monitoring of System Functions and Integrity

In case a failure is detected in one or more of the following functions or data, an alarm will be triggered and displayed on the menu-tree under BIIT List, and the system (transponder) will react as described in the following table.

| Alarm-s description text | Alarm ID | Reaction of the system (transponder) |
|---|----------|--|
| AIS: Tx malfunction | 001 | Stop transmission |
| AIS: Antenna VSWR exceeds limit | 002 | Continue operation |
| AIS: Rx channel 1 malfunction | 003 | Stop transmission on affected channel |
| AIS: Rx channel 2 malfunction | 004 | Stop transmission on affected channel |
| AIS: Rx channel 70 malfunction | 005 | Continue operation |
| AIS: general failure | 006 | Stop transmission |
| AIS: UTC sync invalid | 007 | Continue operation using indirect or semaphore synchronisation |
| AIS: MKD connection lost | 008 | Continue operation |
| AIS: internal / external GNSS position mismatch | 009 | Continue operation |
| AIS: NavStatus incorrect | 010 | Continue operation |
| Heading sensor offset | 011 | Continue operation |
| AIS: active AIS SART | 014 | Continue operation |
| AIS: external EPFS lost | 025 | Continue operation |
| AIS: no sensor position in use | 026 | Continue operation |
| AIS: no valid SOG information | 029 | Continue operation using default data |
| AIS: no valid COG information | 030 | Continue operation using default data |
| AIS: Heading lost/invalid | 032 | Continue operation using default data |
| AIS: no valid ROT information | 035 | Continue operation using default data |

Antenna VSWR Exceeds Limit

There is a built-in RF output power detector, which is used to monitor the VSWR of VHF antenna port. If the antenna VSWR exceeds limit, an alarm will be reported while the unit operates continuously. The system will output an ALR 002 at related PI port.

Detection of Tx Malfunction

A built-in lock detector (high active) is used to monitor the local oscillator (PLL circuit) of the transmitter. If the operation of PLL circuit becomes abnormal, a logic low (TX malfunction) will be sent from the lock detector to notify the system. At the same time, system will also output an ALR 001 at the related PI port.

Detection of Rx Malfunction

The V5035 also has 3 built-in lock detectors (high active) to monitor each local oscillator (PLL circuit) of receiver channel 1, channel 2, and channel 70 respectively. If the operation of PLL circuit becomes abnormal, a logic low level will be sent from the lock detector to notify the system. At the same time, the system will output ALR 003 or ALR 004 or ALR 005 at the related PI port to indicate the CH1 or CH2 or CH70 RX malfunctions respectively.

Appendix C

Installation and maintenance record

The following installation record should be completed and retained on board the vessel for maintenance records.

| Vessel information | | | |
|--------------------|---|-----------------|---|
| Vessel Name | | Flag State | |
| IMO Number | | MMSI Number | |
| Owner/Company | | Radio call sign | |
| Type of vessel | | Gross tonnage | |
| Length | m | Beam | m |

| AIS Class A Transponder information | | | |
|-------------------------------------|---------------|-------------------------|---|
| Transponder S/N | | Pilot Plug S/N | |
| Junction Box S/N | | GPS Ant. S/N | |
| Password | | | |
| Power supply | Voltage: V | Maximum output current: | A |
| Note | | | |

| GPS/GNSS Antenna location | | | |
|---------------------------|---|-----------------------|---|
| A= Distance to Bow | m | C= Dist. To Port-Side | m |
| B= Distance to Stern | m | D= Dist. To Starboard | m |

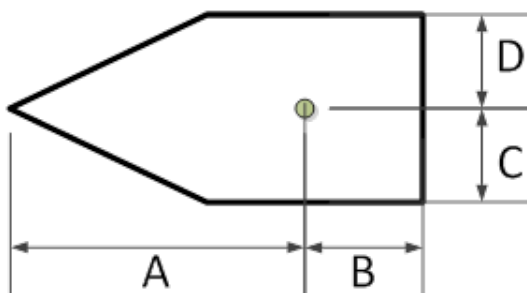

Connected sensors and devices

| Connected Port | Equipment | Model Number |
|------------------|-----------|--------------|
| Sensor 1 | | |
| Sensor 2 | | |
| Sensor 3 | | |
| Ext Display Port | | |
| Pilot Port | | |
| Long Range Port | | |
| DGNSS Data Port | | |
| Other Device | | |

Installer information

| | | |
|-------------------------|------|-----------------------|
| Company name | | |
| Technician's name | | |
| Telephone/mobile number | | |
| Address | | |
| Place | Date | Installer's signature |

Software revisions

The transponder is delivered with software version according to the following table which is to be filled in and maintained either by manufacturer, distributor, dealer, or installer. When software update is done, the new software (firmware) version can be identified through MKD at MENU/DIAGNOSTICS/VERSION (please refer to “Version” page 77 in the manual). Each new software upgrade requires information recorded to reflect the change made.

| Software maintenance record | | | |
|-----------------------------|----|------|--------|
| Software version | By | Date | Change |
| | | | |
| | | | |
| | | | |
| | | | |
| | | | |
| | | | |
| | | | |
| | | | |
| | | | |

Notes



®Reg. U.S. Pat. & Tm. Off, and ™ common law marks.
Visit www.navico.com/intellectual-property to review
the global trademark rights and accreditations for
Navico Holding AS and other entities.

www.navico-commercial.com